

Dell™ 1704FPV Flat Panel Monitor

About Your Monitor

- [Front View](#)
- [Back View](#)
- [Side View](#)
- [Bottom View](#)
- [Monitor Specifications](#)
- [Dell Soundbar \(Optional\) Specifications](#)
- [Caring for Your Monitor](#)

Using Your Adjustable Monitor Stand

- [Attaching the Stand](#)
- [Organizing Your Cables](#)
- [Using the Tilt, Swivel, Vertical Extension](#)
- [Removing the Stand](#)

Setting Up Your Monitor

- [Connecting Your Monitor](#)
- [Using the Front Panel Buttons](#)
- [Using the OSD](#)
- [Setting the Optimal Resolution](#)
- [Using the Dell Soundbar \(Optional\)](#)

Rotating Your Monitor

- [Changing the Rotation of Your Monitor](#)
- [Rotating Your Operating System](#)

Solving Problems

- [Troubleshooting Your Monitor](#)
- [General Problems](#)
- [Product Specific Problems](#)
- [USB Problems](#)
- [Troubleshooting Your Soundbar](#)

Appendix

- [Warranty](#)
- [Safety Information](#)
- [Contacting Dell](#)
- [Regulatory Notices](#)
- [Recycling](#)
- [Your Monitor Set-up Guide](#)

Information in this document is subject to change without notice.

© 2004 Dell Inc. All rights reserved.

Reproduction in any manner whatsoever without the written permission of Dell Inc. is strictly forbidden.

Trademarks used in this text: *Dell™*, *PowerEdge™*, *PowerConnect™*, *PowerVault™*, *Dell™ Dimension™*, *Inspiron™*, *OptiPlex™*, *Latitude™*, *Dell Precision™* and *Dell | EMC* are trademarks of Dell Inc; *Microsoft*, *Windows* and *Windows NT* are registered trademarks of Microsoft Corporation; *Adobe* is a trademark of Adobe Systems Incorporated, which may be registered in certain jurisdictions. *ENERGY STAR* is a registered trademark of the U.S. Environmental Protection Agency. As an ENERGY STAR partner, Dell Inc. has determined that this product meets the ENERGY STAR guidelines for energy efficiency. *EMC* is a registered trademark of EMC Corporation.

Other trademarks and trade names may be used in this document to refer to either the entities claiming the marks and names or their products. Dell Inc. disclaims any proprietary interest in trademarks and trade names other than its own.

August 2004

About Your Monitor

Dell™ 1704FPV Flat Panel Monitor

- [Front View](#)
 - [Back View](#)
 - [Bottom View](#)
 - [Side View](#)
 - [Monitor Specifications](#)
 - [Dell Soundbar \(Optional\) Specifications](#)
 - [Caring for Your Monitor](#)
-

Front View

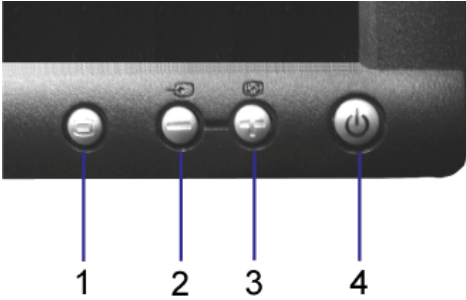

1. OSD menu / select button
 2. Input select / down button
 3. Auto-adjust / up button
 4. Power button (with power light indicator)
-

Back View



1. Dell Soundbar mounting brackets — Attach the optional Dell Soundbar.
2. Security lock slot — Attach a lock to secure your monitor.
3. Stand removal button — Press to release the stand.
4. VESA mounting holes (100mm [Behind attached base plate]) — Use to mount the monitor.
5. Barcode serial number label — Refer to this label if you need to contact Dell for technical support
6. Lock down/release button — Push the monitor down, press the button to unlock the monitor, and then lift the monitor to the desired height.
7. Regulatory rating label — Lists the regulatory approvals.
8. Cable holder — Help organize cables by placing them in the holder.

Bottom View

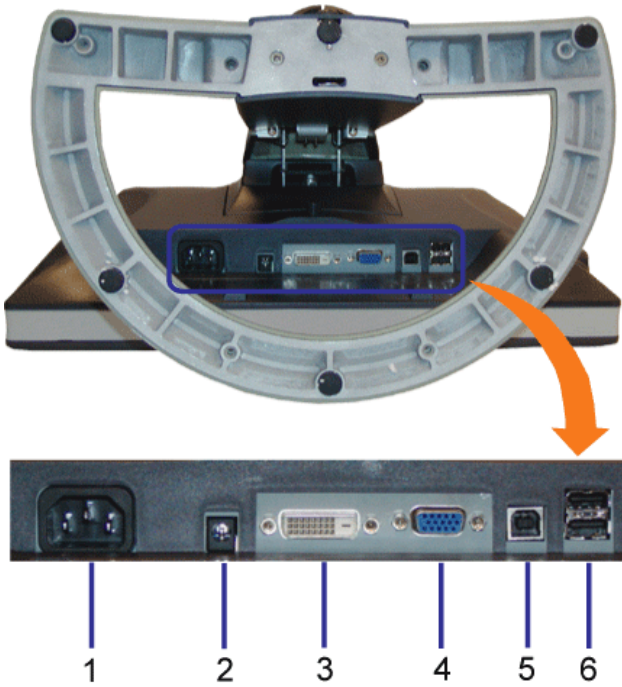

1. Power connector - Connect the power cable
2. Dell Soundbar power connector - Connect the power cord for the Soundbar (optional)
3. DVI connector - Connect your computer DVI cable
4. VGA connector - Connect your computer VGA cable
5. USB upstream connector - Connect the USB cable that came with your monitor to the monitor and the computer. Once this cable is connected you can use the USB connectors on the side and bottom of the monitor.
6. USB connector - Connect your USB devices. You can only use this connector after you have connected the USB cable to the computer and USB upstream connector on the monitor.

Side View

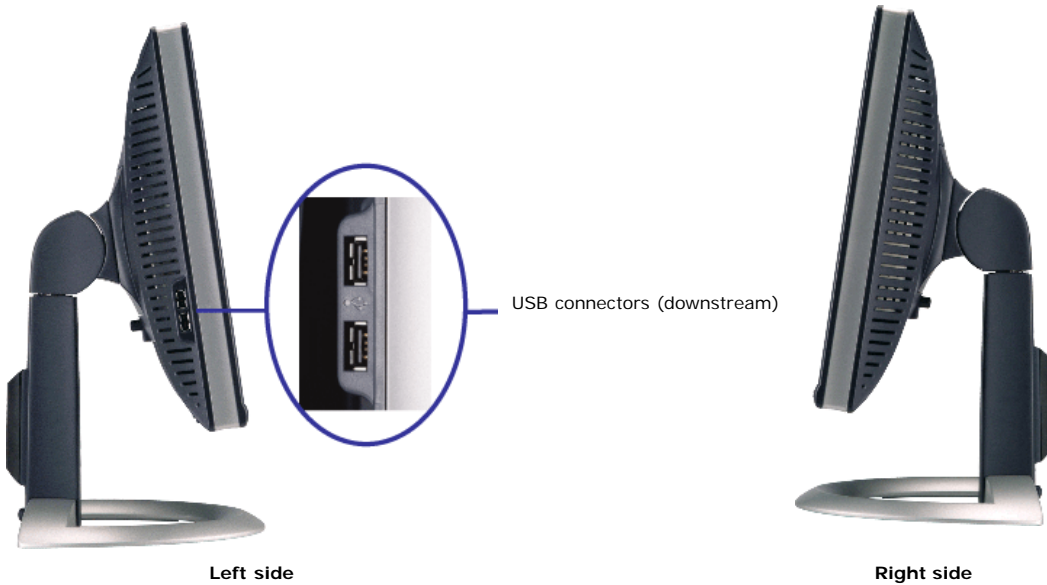

Left side

Right side

Monitor Specifications

Power Management Modes

If you have VESA's DPM™ compliance display card or software installed in your PC, the monitor can automatically reduce its power consumption when not in use. This is referred to as 'Power Save Mode'*. If input from keyboard, mouse or other input devices is detected by the computer, the monitor will automatically "wake up". The following table shows the power consumption and signaling of this automatic power saving feature:

VESA Modes	Horizontal Sync	Vertical Sync	Video	Power Indicator	Power Consumption
Normal operation(with Dell Soundbar and USB active)	Active	Active	Active	Green	65 W (maximum)
Normal operation	Active	Active	Active	Green	32 W (typical)
Active-off mode	Inactive	Inactive	Blanked	Amber	Less than 3 W
Switch off	-	-	-	Off	Less than 1 W

NOTE: The OSD will only function in the 'normal operation' mode. Otherwise one of the following messages will appear when the "menu" or "plus" buttons are pressed when in Active-off mode.

1. Analog Input
In Power Save Mode
Press Any Key on Keyboard or Move Mouse

or

2. Digital Input
In Power Save Mode
Press Any Key on Keyboard or Move Mouse

Activate the computer and 'wake up' the monitor to gain access to the [OSD](#).

This monitor is **ENERGY STAR®**-compliant as well as TCO '99 / TCO '03 power management compatible.



* Zero power consumption in OFF mode can only be achieved by disconnecting the main cable from the monitor.

ENERGY STAR® is a U.S. registered mark. As an **ENERGY STAR®** Partner, DELL has determined that this product meets the **ENERGY STAR®** guidelines for energy efficiency.

Pin Assignments

15-pin D-Sub connector:

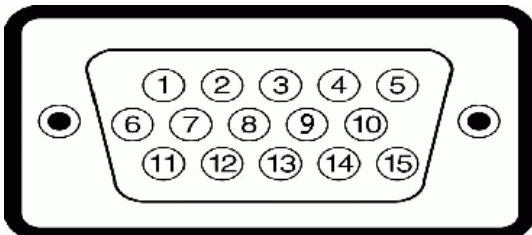

Pin Number	Monitor Side of the 15-Pin Side Signal Cable

1	Video-Red
2	Video-Green
3	Video-Blue
4	GND
5	GND
6	GND-R
7	GND-G
8	GND-B
9	DDC +5V
10	Sync/self-test
11	GND
12	DDC data
13	H-sync
14	V-sync
15	DDC clock

24 pin digital-only DVI connector:

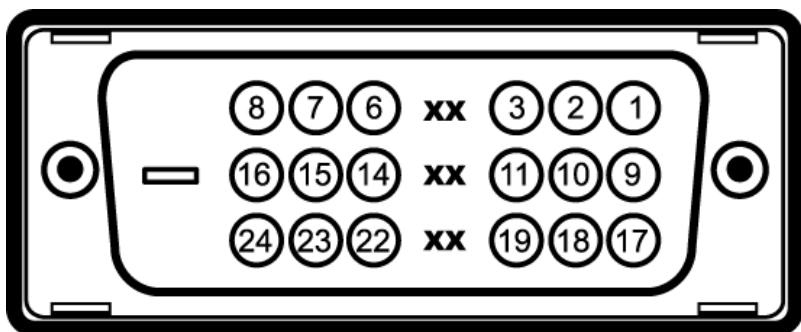

Note: Pin 1 is at the top right.

Pin	Signal Assignment	Pin	Signal Assignment	Pin	Signal Assignment
1	T.M.D.S. Data 2-	9	T.M.D.S. Data 1-	17	T.M.D.S. Data 0-
2	T.M.D.S. Data 2+	10	T.M.D.S. Data 1+	18	T.M.D.S. Data 0+
3	T.M.D.S. Data 2 Shield	11	T.M.D.S. Data 1 Shield	19	T.M.D.S. Data 0 Shield
4	No Pin	12	No Pin	20	No Pin
5	No Pin	13	No Pin	21	No Pin
6	DDC Clock	14	+5V Power	22	T.M.D.S. Clock Shield
7	DDC Data	15	Ground (for +5V)	23	T.M.D.S. Clock +
8	No Connect	16	Hot Plug Detect	24	T.M.D.S. Clock -

Universal Serial Bus (USB) Interface

This monitor supports High-Speed Certified USB 2.0 interface. *



	Data Rate	Power Consumption
High speed	480 Mbps	2.5W (Max., each port)
Full speed	12 Mbps	2.5W (Max., each port)
Low speed	1.5 Mbps	2.5W (Max., each port)

USB ports:

- 1 upstream - rear
- 4 downstream - 2 on rear; 2 on left side

NOTE: USB 2.0 capability requires 2.0 capable computer

NOTE: Monitor's USB interface works ONLY when monitor is Powered ON (or in Power Save Mode). Switching your monitor OFF and then ON would re-enumerate its USB interface; attached peripherals may take a few seconds to resume normal functionality.

Plug and Play Capability

You can install the monitor in any Plug and Play-compatible system. The monitor automatically provides the computer system with its Extended Display Identification Data (EDID) using Display Data Channel (DDC) protocols so the system can configure itself and optimize the monitor settings. If desired, the user can select different settings, but in most cases monitor installation is automatic.

General

Model number 1704FPV

Flat Panel

Screen type Active matrix - TFT LCD
Screen dimensions 17 inches (17-inch viewable image size)
Preset display area:
Horizontal 337 mm (13.3 inches)
Vertical 270 mm (10.6 inches)
Pixel pitch 0.264 mm
Viewing angle 178° (vertical) typ, 178° (horizontal) typ
Luminance output 280 CD/m²(typ)
Contrast ratio 1000 to 1 (typ)
Faceplate coating Antiglare with hard-coating 3H
Backlight CCFL (4) edgelight system
Response Time 25ms typical

Resolution

Horizontal scan range 30 kHz to 81 kHz (automatic)
Vertical scan range 56 Hz to 76 Hz (automatic)
Optimal preset resolution 1280 x 1024 at 60 Hz
Highest preset resolution 1280 x 1024 at 75 Hz

Preset Display Modes

Display Mode	Horizontal Frequency (kHz)	Vertical Frequency (Hz)	Pixel Clock (MHz)	Sync Polarity (Horizontal/Vertical)
VESA, 720 x 400	31.5	70.0	28.3	-/+
VESA, 640 x 480	31.5	60.0	25.2	-/-
VESA, 640 x 480	37.5	75.0	31.5	-/-
VESA, 800 x 600	37.9	60.3	49.5	+/+
VESA, 800 x 600	46.9	75.0	49.5	+/+
VESA, 1024 x 768	48.4	60.0	65.0	-/-
VESA, 1024 x 768	60.0	75.0	78.8	+/+
VESA, 1152 x 864	67.5	75.0	108	+/+
VESA, 1280 x 1024	64.0	60.0	135.0	+/+
VESA, 1280 x 1024	80.0	75.0	135.0	+/+

Electrical

Video input signals Analog RGB, 0.7 Volts +/-5%, positive polarity at 75 ohm input impedance
Digital DVI-D TMDs, 600mV for each differential line, positive polarity at 50 ohm input impedance
Synchronization input signals Separate horizontal and vertical synchronizations, polarity-free TTL level, SOG (Composite SYNC)

AC input voltage / frequency / current	on green) 100 to 240 VAC / 50 or 60 Hz \pm 3 Hz / 2.0A (Max.)
Inrush current	120V: 42A (Max.) 240V: 80A (Max.)

Physical Characteristics

Connector type	15-pin D-subminiature, blue connector; DVI-D, white connector
Signal cable type	Analog: Detachable, D-sub, 15pin, shipped attached to the monitor Digital: Detachable, DVI-D, Solid pins, shipped detached from the monitor
Dimensions (with stand):	
Height (fully extended in portrait mode)	548.21 mm (21.58 inches)
Height (compressed/locked in landscape mode)	384.36 mm (15.13 inches)
Width	376 mm (14.8 inches)
Depth	213.79 mm (8.42 inches)
Weight (monitor only)	6.12 Kg (13.48 lb)
Weight (with packaging)	8.3 Kg (18.28 lb)

Environmental

Temperature:	
Operating	5° to 35°C (41° to 95°F)
Nonoperating	Storage: -20° to 60°C (-4° to 140°F) Shipping: -20° to 60°C(-4° to 140°F)
Humidity:	
Operating	10% to 80% (noncondensing)
Nonoperating	Storage: 5% to 90% (noncondensing) Shipping: 5% to 90%(noncondensing)
Altitude:	
Operating	3,657.6m (12,000 ft) max
Nonoperating	12,192 m (40,000 ft) max
Thermal dissipation	221.937 BTU/hour (maximum) 109.261 BTU/hour (typical)

Dell Soundbar (Optional) Specifications

System Frequency Response	95 Hz to 20 kHz @ 10 dB below avg. SPL
Total Power Output	14 W continuous average power (all speakers operating) @ 10% (THD+N), 1 kHz (FTC rated)
Headphone Jack Output Power	40 mW continuous average power (RL = 32 Ω) @ 10% (THD+N), 1 kHz
Input Sensitivity for Rated Output	500 \pm 50 mVrms @ 1 kHz
Input Impedance	>10k Ω
Maximum Input Signal Voltage	2 Vrms
Controls	Power On/Off Volume Control
Input Cables	3.0 m \pm 0.1 m AWG26 black cable attached to enclosure, with 3.5 mm lime green stereo plug
Power Requirements	DC12V, 1.5A +/-10%
Power Cord Length	305 mm \pm 15 mm AWG22 black cable attached to enclosure, with DC plug (5.5 x 2.1 x 12 mm)
Operating Temperature Range	10°C to 40°C
Humidity, Non-condensing	95% RH @ 40 °C

Caring for Your Monitor

 **CAUTION:** Read and follow the [safety instructions](#) before cleaning the monitor.

 **CAUTION:** Before cleaning the monitor, unplug the monitor from the electrical outlet.

- To clean your antistatic screen, lightly dampen a soft, clean cloth with water. If possible, use a special screen-cleaning tissue or solution suitable for the antistatic coating. Do not use benzene, thinner, ammonia, abrasive cleaners, or compressed air.
 - Use a lightly-dampened, warm cloth to clean the plastics. Avoid using detergent of any kind as some detergents leave a milky film on the plastics.
 - If you notice a white powder when you unpack your monitor, wipe it off with a cloth. This white powder occurs during the shipping of the monitor.
 - Handle your monitor with care as darker-colored plastics may scratch and show white scuff marks more than lighter-colored monitor.
-

[Back to Contents Page](#)

Using Your Adjustable Monitor Stand

Dell™ 1704FPV Flat Panel Monitor

- [Attaching the Stand](#)
 - [Organizing Your Cables](#)
 - [Using the Tilt, Swivel, and Vertical Extension](#)
 - [Removing the Stand](#)
-

Attaching the Stand

 **NOTE:** The stand is detached and extended when the monitor is shipped from the factory.



1. Fit the groove on the of the monitor onto the three teeth on stand.
 2. Lower the monitor until it locks in to place on the stand.
-

Organizing Your Cables



After attaching all necessary cables to your monitor and computer, (See [Connecting Your Monitor](#) for cable attachment,) use the cable holder to neatly organize all cables as shown above.

Using the Tilt, Swivel, and Vertical Extension

Adjusting Your Monitor Using Tilt, Swivel, and Vertical Extension. You can adjust your monitor to best fit your viewing needs.

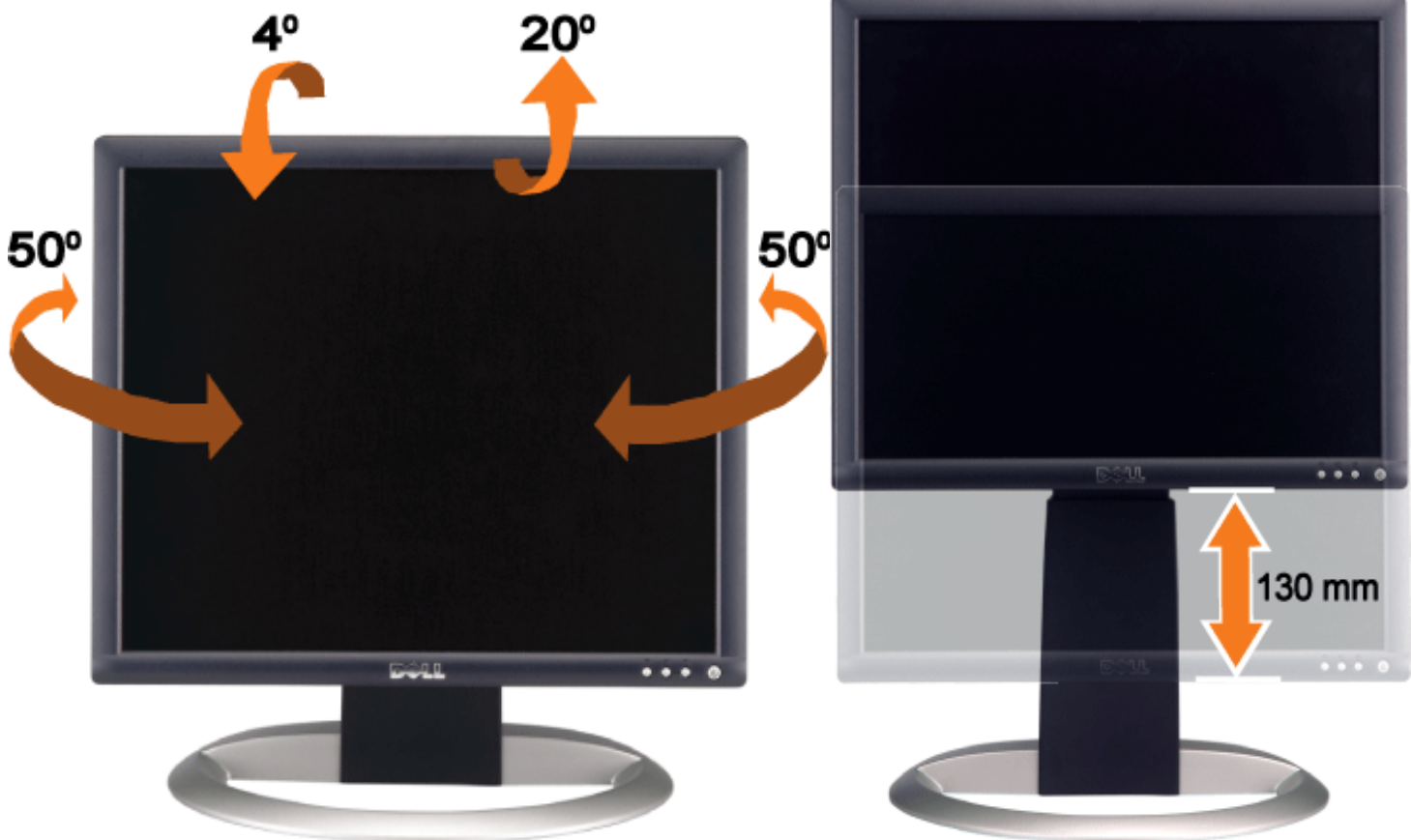

You can adjust the stand vertically, up to 5.12 inches (130mm) using the stand lock/release button. Press the stand lock/release button on the back of the monitor and then lift or lower the stand to the desired position.

NOTE: Before you move the monitor to a new location, lock the stand by lowering monitor until it clicks in to place.

Removing the Stand

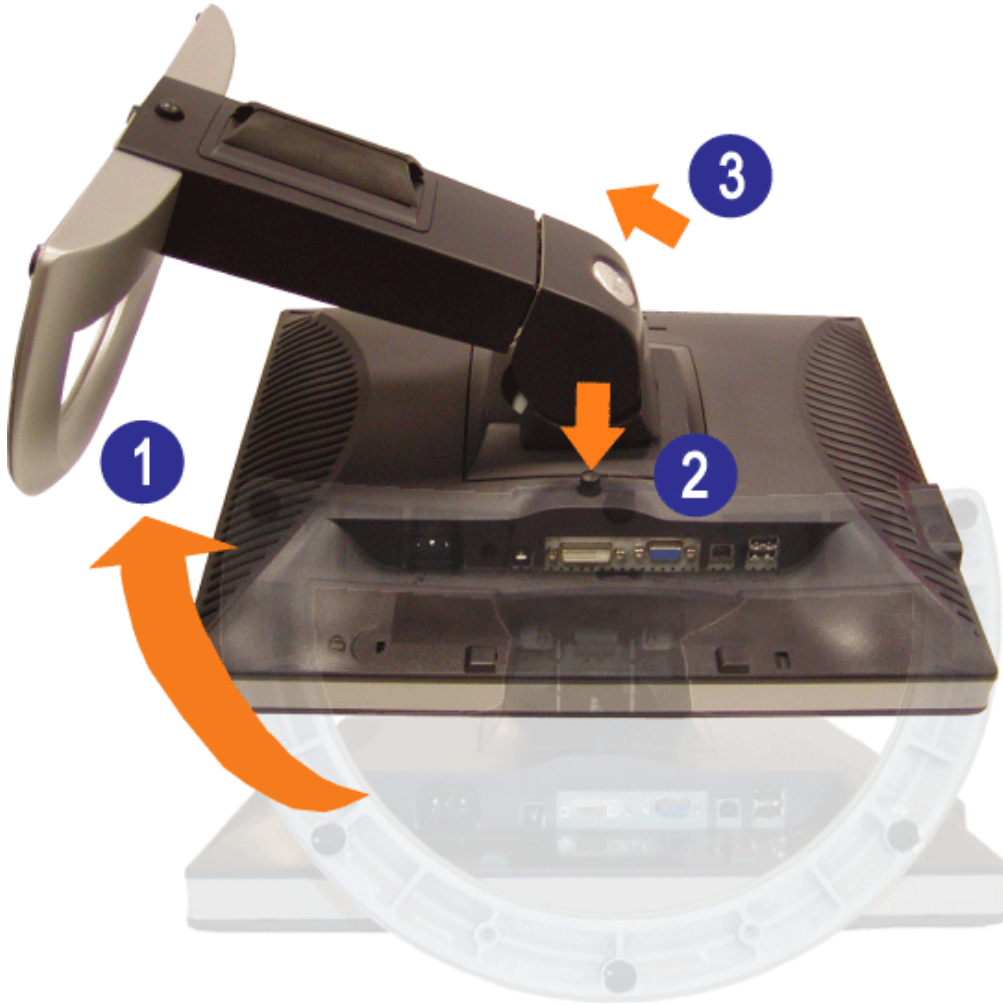

⚠ NOTICE: After placing the monitor panel on soft cloth or cushion, complete the following steps to remove the stand.

1. Rotate the stand to allow access to the stand removal button.
2. Press and hold the stand removal button while lifting the monitor up and away from the stand.

[Back to Contents Page](#)

Setting Up Your Monitor

Dell™ 1704FPV Flat Panel Monitor

- [Connecting Your Monitor](#)
- [Using the Front Panel Buttons](#)
- [Using the OSD](#)
- [Setting the Optimal Resolution](#)
- [Using the Dell Soundbar \(Optional\)](#)

Connecting Your Monitor

CAUTION: Before you begin any of the procedures in this section, follow the [safety instructions](#).

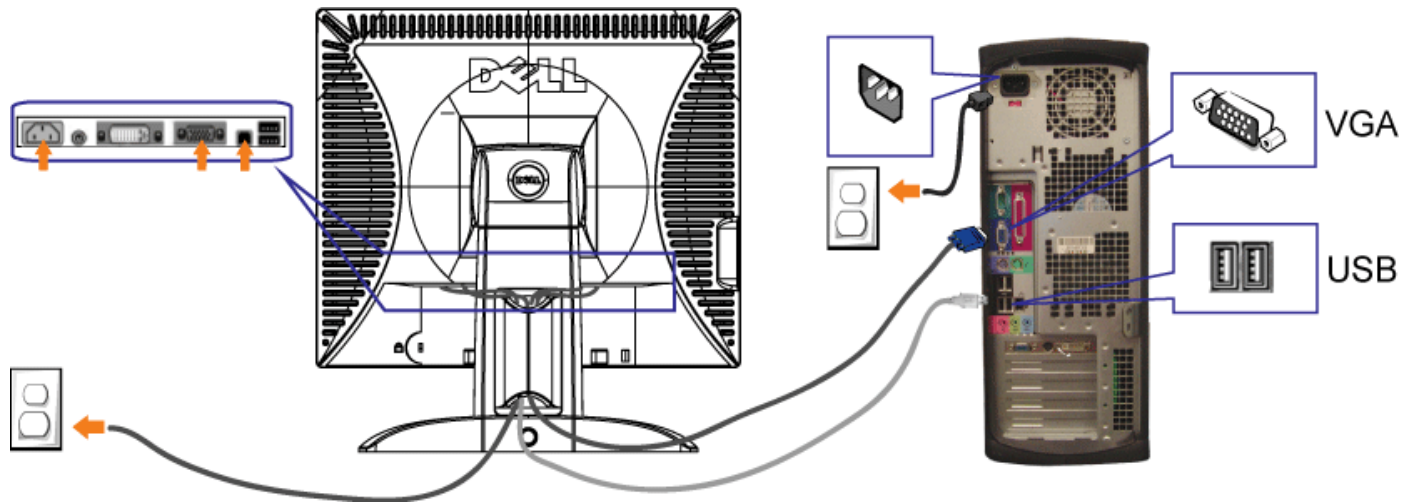

or

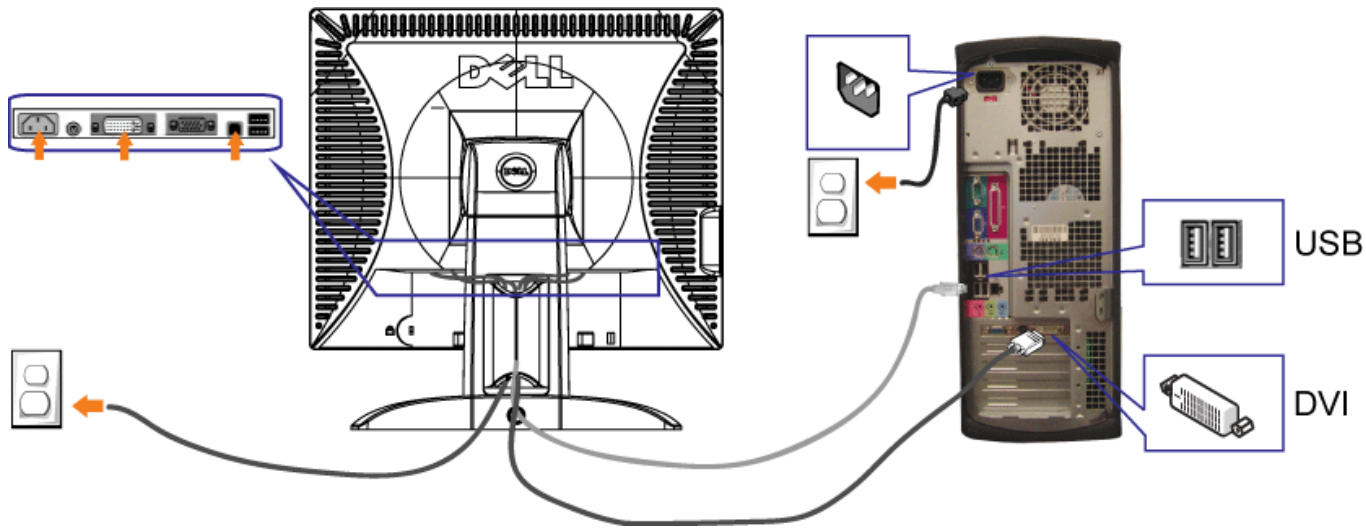



1. Turn off your computer and disconnect the power cable.
2. Connect either the white DVI or blue VGA cables to the connectors on the computer and the monitor.
3. Connect the USB cable that was included with your monitor to the computer and the upstream USB connector on the monitor. Once this cable is connected to the computer and the monitor, you can use the USB connectors on the monitor.
4. Connect any USB devices.
5. Connect the power cables
6. Turn on your monitor and computer. If you do not see an image, push the input select button and ensure the correct input source is selected. If you still do not see an image, see [Troubleshooting Your Monitor](#).

Using the Front Panel Buttons

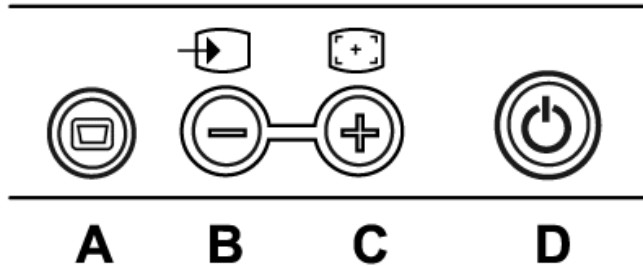
Use the buttons on the front of the monitor to adjust the image settings.



 <p>OSD menu / select</p>	<p>The Menu button is used to open the on-screen display (OSD), exit from menus and sub-menus, and to exit the OSD. See Using the OSD</p>
	<p>Use the Input Select button to select between two different video signals that may be connected to your monitor.</p> <p> NOTE: The floating 'Dell - self-test Feature Check' dialog appears (against a black background) if the monitor cannot sense a video signal. Depending upon the selected input, one of the dialogs shown below will scroll continually.</p>



Input select

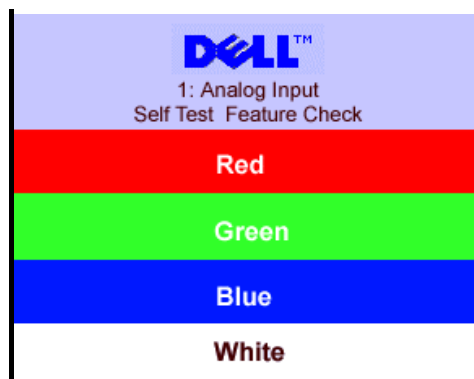

or

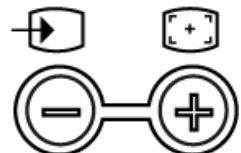
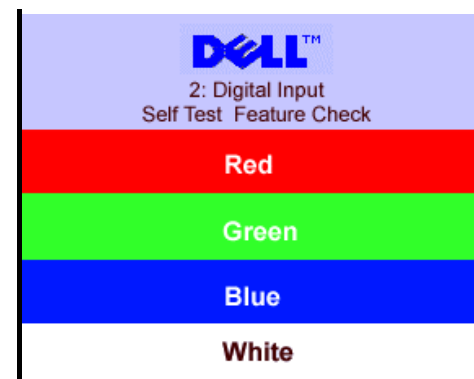

Down (-) and Up (+)

Use these buttons to adjust (decrease/increase ranges) items in the OSD.



Auto Adjust

Use this button to activate automatic setup and adjustment. The following dialog appears on a black screen as the monitor self-adjusts to the current input:

Auto Adjust In Progress

Auto Adjustment  button allows the monitor to self-adjust to the incoming video signal. After using Auto Adjustment, you can further tune your monitor by using the Pixel Clock (Coarse), Phase (Fine) controls in the OSD.

 **NOTE: Auto Adjust does not occur if you press the button while there are no active video input signals or attached cables.**



Power Button and Indicator

Use the power button to turn the monitor on and off.

The green light indicates the monitor is on and fully functional. An amber light indicates power save mode.

Using the OSD

 **NOTE: If you make an adjustment and then either proceed to another menu, or exit the OSD, the monitor automatically saves any adjustments you have made. If you make an adjustment and then wait for the OSD to disappear the adjustment are saved.**

1. Push the MENU button to open the OSD system and display the main menu.

Main Menu for Analog (VGA) Input

Main Menu for Digital (DVI) Input



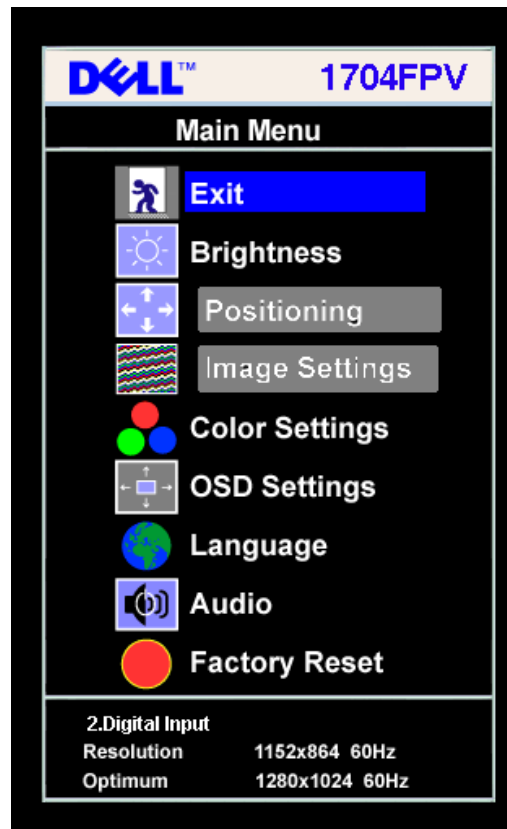

or



 **NOTE: Positioning and Image settings are only available when you are using the Analog (VGA) connector.**

2. Push the - and + buttons to move between the setting options. As you move from one icon to another, the option name is highlighted. See the table below for a complete list of all the options available for the monitor.
3. Push the MENU button once to activate the highlighted option.
4. Push - and + button to select the desired parameter.
5. Push menu to enter the slide bar and then use the - and + buttons, according to the indicators on the menu, to make your changes.
6. Push the Menu button once to return to the main menu to select another option or push the Menu button two or three times to exit from the OSD.

Icon	Menu and Submenus	Description
	Exit	Select to exit the Main menu
	Brightness/ Contrast	<p>Brightness adjusts the luminance of the backlight. Adjust Brightness first, then adjust Contrast only if further adjustment is necessary. Push the + button to increase luminance and push the - button to decrease luminance (min 0 ~ max 100).</p> <p>Contrast adjusts the degree of difference between darkness and lightness on the monitor screen. Push the + button to increase the contrast and push the - button to decrease the contrast (min 0 ~ max 100).</p>

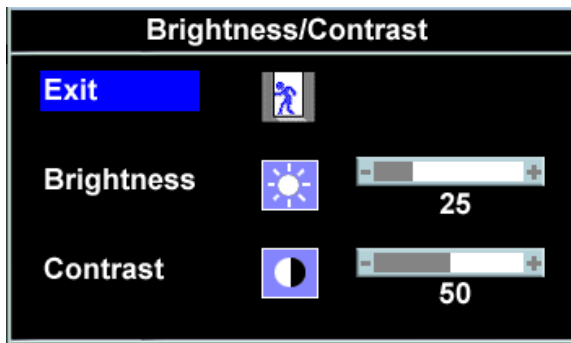

NOTE: When using DVI source, the contrast adjustment is not available



**Positioning:
Horizontal
Vertical**

Positioning moves the viewing area around on the monitor screen.

When making changes to either the Horizontal or Vertical settings, no changes occur to the size of the viewing area, the image shifts in response to your selection.

Minimum is 0 (-) and maximum is 100 (+).

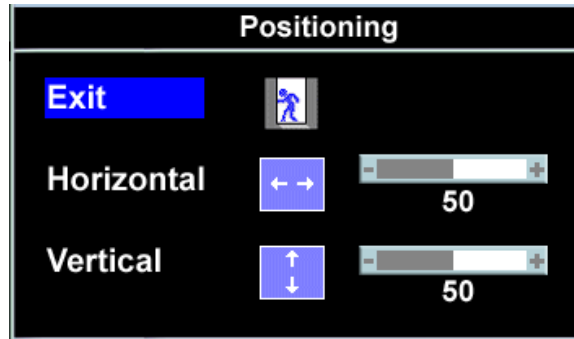

NOTE: When using DVI source, the Positioning option is not available

NOTE: Horizontal and Vertical OSD positioning adjusts with respect to landscape (default) or portrait [display rotation](#) when used in conjunction with the [OSD rotation](#) feature.

**Image settings:
Auto Adjust**

Even though your computer recognizes your monitor on startup, the Auto Adjustment function optimizes the display settings for use with your particular setup.

NOTE: In most cases, Auto Adjust produces the best image for your configuration.



**Pixel Clock
(Coarse)**

The Phase and Pixel Clock adjustments allow you to more closely adjust your monitor to your preference. These settings are accessed through the main OSD menu, by selecting Image Settings.



Phase (Fine)

Use the - and + buttons to make adjustments. (Minimum: 0 ~ Maximum: 100)

If satisfactory results are not obtained using the Phase adjustment, use the Pixel Clock (course) adjustment and then use Phase (fine), again.

NOTE: This function may change the width of the display image. Use the Horizontal function of the Position menu to center the display image on the screen.

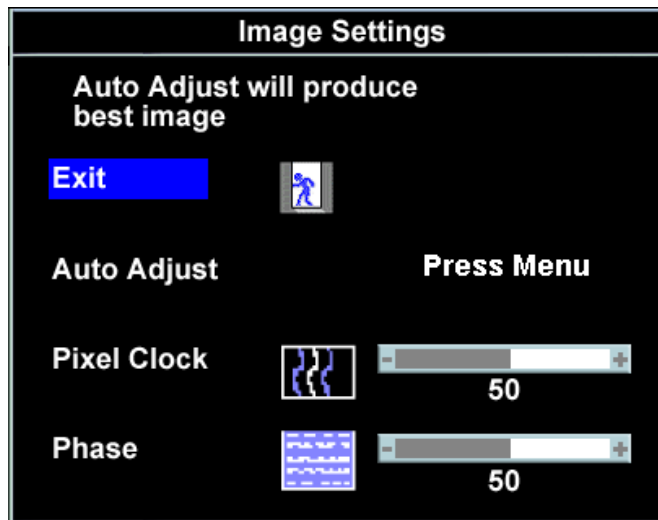

 **NOTE:** When using DVI source, the Image Settings option is not available.



Color Settings

Color Settings adjusts the color temperature, color hue, and saturation.

The color hue is most noticeable in areas of white.

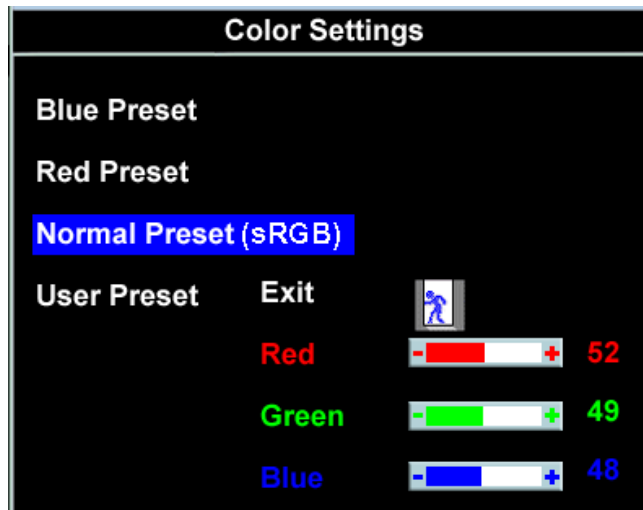

Blue Preset

Red Preset

Normal Preset

User Preset

- Blue Preset is selected to obtain a bluish tint. This color setting is typically used for text based applications (spreadsheets, programming, text editors etc.).
- Red Preset is selected to obtain a redder tint. This color setting is typically used for color intensive applications (photograph image editing, multimedia, movies etc.).
- Normal Preset is selected to obtain the default (factory) color settings. This setting is also the “sRGB” standard default color space.
- User Preset: Use the plus and minus buttons to increase or decrease each of the three colors (R, G, B) independently, in single digit increments, from 0 to 100.

OSD Settings:

Adjust the settings for the OSD, including the location, the amount of time the menu remains on-screen, and the rotation of the OSD.

Horizontal Position

Position of the OSD:

- To adjust the horizontal position of the OSD, use the - and + buttons move OSD to the left and right.



Vertical Position



OSD Hold Time



OSD Rotation



OSD Lock

- To adjust the vertical position of the OSD, use the - and + buttons move OSD down and up.

OSD Hold Time:

The OSD stays active for as long as it is in use. Adjust the hold time, sets the length of time the OSD remains ctive after the last time you pressed a button. Use the - and + buttons to adjust the slider in 5 second increments, from 5 to 60 seconds.

OSD Rotation:

Rotates the OSD by 90 ° counter-clockwise. Adjust according to [Rotating Your Monitor](#) setction

OSD Lock:

Controls user access to adjustments. When Yes (+) is selected, no user adjustments are allowed. All buttons are locked except the menu button.

NOTE: When the OSD is locked, pressing the menu button takes the user directly to the OSD settings menu, with OSD Lock selected. Select No (-) to unlock and allow user access to all applicable settings.

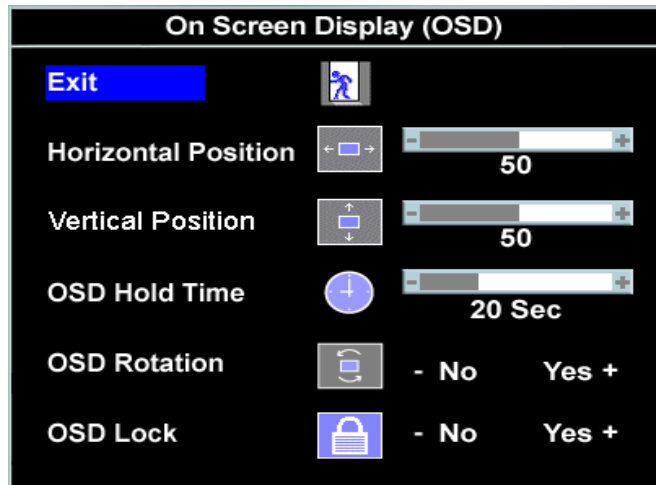

NOTE: You can also lock or unlock the OSD by pushing and holding the Menu button for 15 seconds.



Language

Select to have the OSD display in one of five languages (English, French, Spanish, German or Japanese).



NOTE: The change only affects the OSD, it has no effect on any software running on the computer.

Audio

You can select to have the audio on or off when the monitor is power saving mode.



(optional)

Yes — enables audio
No — disables audio (default)

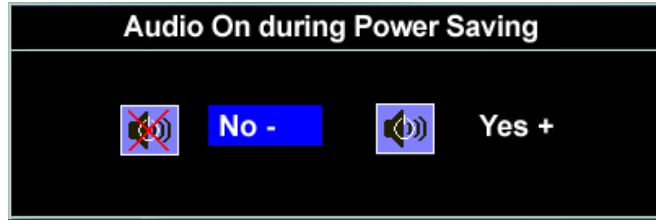

NOTE: When the Dell Soundbar is not properly connected to the monitor, the audio menu is not available.



Factory Reset:

Reset the OSD menu options to the factory preset values.

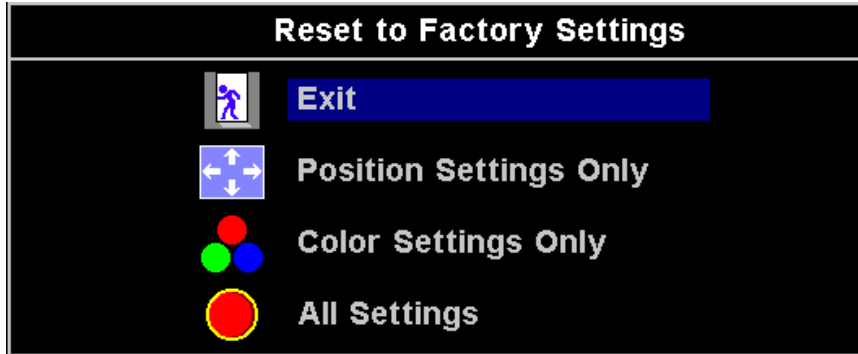

Exit — Select to exit out of Factory Reset menu without resetting any OSD options.

Position settings only — Change the settings for Image Position back to original factory settings.

Color settings only — Change the Red, Green, and Blue settings back to their original factory settings and set the default setting for Normal Preset.

All settings — Change all the user adjustable settings including color, position, brightness, contrast and OSD hold time to the factory defaults. The language of the OSD does not change.

OSD Warning Messages

One of the following warning messages may appear on the screen indicating that the monitor is out of sync.

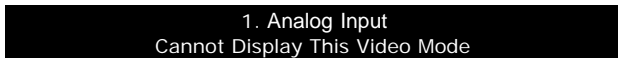

or

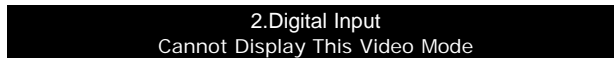

This means that the monitor cannot synchronize with the signal that it is receiving from the computer. Either the signal is too high or too low for the monitor to use. See [Specifications](#) for the Horizontal and Vertical frequency ranges addressable by this monitor. Recommended mode is 1280 X 1024 @ 60Hz.

NOTE: The floating Dell Self-test Feature Check dialog appears on-screen if the monitor cannot sense a video signal.

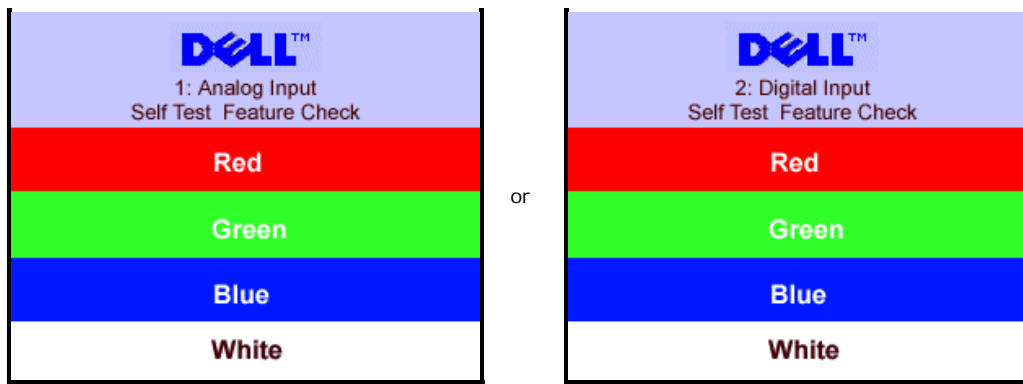

Occasionally, no warning message appears, but the screen is blank, this could also indicate that the monitor is not synchronizing with the computer.

See [Solving Problems](#) for more information.

Setting the Optimal Resolution

1. Right-click on the desktop and click **Properties**.
2. Select the **Settings** tab.
3. Set the refresh rate to 60 Hz.
4. Set the screen resolution to 1280 x 1024 and ensure the refresh rate is still set at 60 Hz.
5. Click **OK**.

If you do not see 1280 x 1024 as an option, you may need to update your graphics driver.

If you have a Dell desktop computer you can do the following:

- Go to support.dell.com, enter your service tag, and download the latest driver for your graphics card.

If you have a Dell portable computer:

- Go to support.dell.com, enter your service tag, and download the latest driver for your graphics card.

If you are using a non-Dell computer:

- Go to the support site for your computer and download the latest graphic drivers
 - Go to your graphics card website and download the latest graphic drivers
-

Using the Dell Soundbar (Optional)

The Dell Soundbar is a four-speaker, two-channel speaker that can be attached to your monitor. Located on the Soundbar are a: Rotary volume and on/off control to adjust the overall system level, a green LED for power indication, and two audio headset jacks.



1. Attach mechanism
2. Power/volume control
3. Power indicator
4. Headphone connectors

Soundbar Attachment to the Monitor

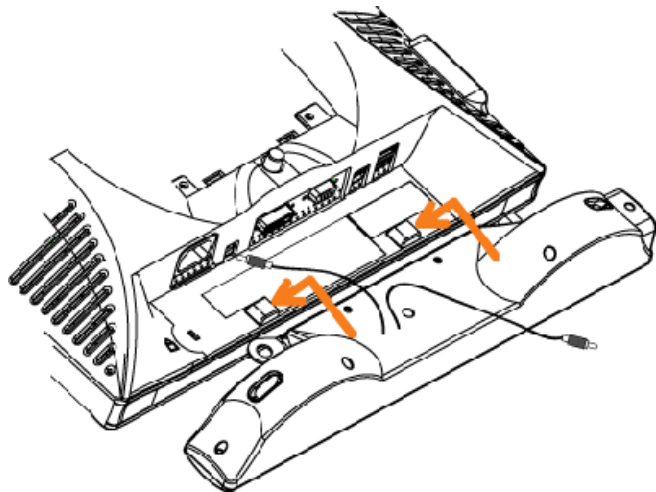

NOTICE: Do not use the soundbar power connector with any other device.



1. Attach the Soundbar by aligning the two slots on the Soundbar with the two tabs on the bottom of the monitor.
2. Slide the Soundbar to the left until it snaps in to place.
3. Plug in the power cord from the Soundbar in to the connector on the back of the monitor.
4. Insert the green stereo plug from the Soundbar in to your computer's audio output connector.

[Back to Contents Page](#)

Rotating Your Monitor

Dell™ 1704FPV Flat Panel Monitor

- [Changing the Rotation of Your Monitor](#)
 - [Rotating Your Operating System](#)
-

Changing the Rotation of Your Monitor

Before you rotate the monitor, your monitor should either be vertically extended ([Vertical Extension](#)) or tilted ([Tilt](#)) to avoid hitting the bottom edge of the monitor.



Rotating Your Operating System

After you have rotated your monitor, you need to complete the procedure below to rotate your operating system.

NOTE: If you are using the monitor with a non-Dell computer, you need to go the graphics driver website or your computer manufacturer website for information on rotating your operating system.

1. Right-click on the desktop and click **Properties**.
2. Select the **Settings** tab and click **Advanced**.
3. If you have ATI, select the **Rotation** tab and set the preferred rotation.
If you have nVidia, click the **nVidia** tab, in the left-hand column select **NVRotate**, and then select the preferred rotation.
If you have Intel, select the **Intel** graphics tab, click **Graphic Properties**, select the **Rotation** tab, and then set the preferred rotation.

NOTE: If you do not see the rotation option or it is not working correctly, go to support.dell.com and download the latest driver for your graphics card.

Solving Problems

Dell™ 1704FPV Flat Panel Monitor

- [Troubleshooting Your Monitor](#)
- [General Problems](#)
- [Product Specific Problems](#)
- [USB Problems](#)
- [Troubleshooting Your Soundbar](#)

CAUTION: Before you begin any of the procedures in this section, follow the [safety instructions](#).

Troubleshooting Your Monitor

Self-Test Feature Check (STFC)

Your monitor provides a self-test feature that allows you to check whether your monitor is functioning properly. If your monitor and computer are properly connected but the monitor screen remains dark, run the monitor self-test by performing the following steps:

1. Turn off both your computer and the monitor.
2. Unplug the video cable from the back of the computer. To ensure proper Self-Test operation, remove both Digital (white connector) and the Analog (blue connector) cables from the back of computer.
3. Turn on the monitor.

The floating 'Dell - Self-Test Feature Check' dialog box should appear on-screen (against a black background) if the monitor cannot sense a video signal and is working correctly. While in self-test mode, the power LED remains green. Also, depending upon the selected input, one of the dialogs shown below will continuously scroll through the screen.

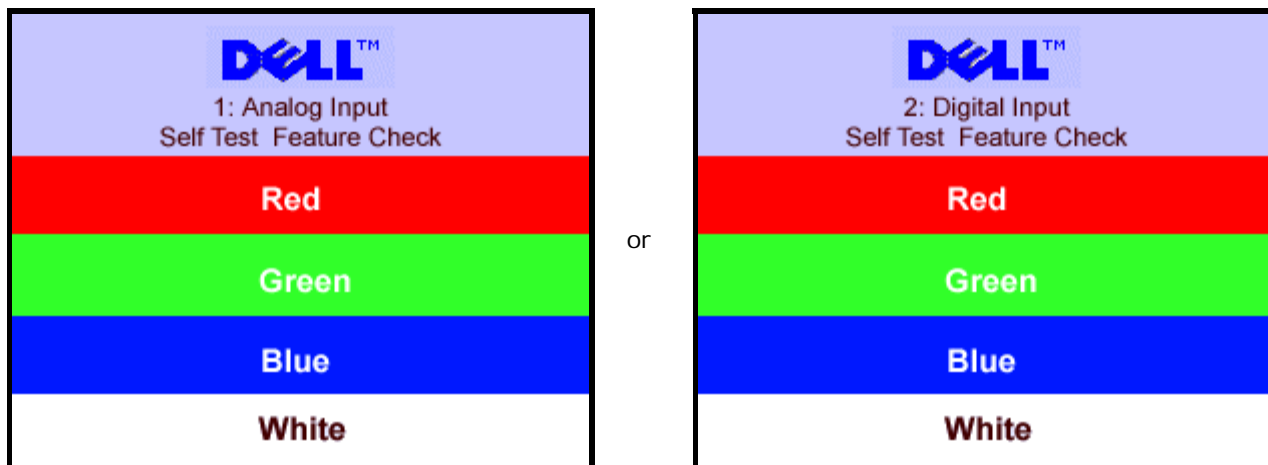

This box also appears during normal system operation if the video cable becomes disconnected or damaged.

4. Turn off your monitor and reconnect the video cable; then turn on both your computer and the monitor.

If your monitor screen remains blank after you use the previous procedure, check your video controller and computer system; your monitor is functioning properly.

OSD Warning Messages

One of the following warning messages may appear on the screen indicating that the monitor is out of sync.

**1. Analog Input
Cannot Display This Video Mode** or **2. Digital Input
Cannot Display This Video Mode**

This means that the monitor cannot synchronize with the signal that it is receiving from the computer. Either the signal is too high or too low for the monitor to use. See [Monitor Specifications](#) for the Horizontal and Vertical frequency ranges addressable by this monitor. Recommended mode is 1280 X 1024 @ 60Hz.

Occasionally, no warning message appears, but the screen is blank...this could also indicate that the monitor is not synchronizing with the computer or the monitor is in a power save mode.

General Problems

The following table contains general information about common monitor problems you might encounter.

COMMON SYMPTOMS	WHAT YOU EXPERIENCE	POSSIBLE SOLUTIONS
No Video/ Power LED off	No picture, monitor is dead	<ul style="list-style-type: none">• Check connection integrity at both ends of the video cable• Ensure the monitor and computer are plugged in to a working electrical outlet• Ensure power button depressed fully
No Video/ Power LED on	No picture or no brightness	<ul style="list-style-type: none">• Press the input select button the front of the monitor and ensure the correct input source is selected• Increase brightness & contrast controls• Perform monitor self-test feature check• Check for bent or broken pins• Re-boot your computer and monitor.
Poor Focus	Picture is fuzzy, blurry or ghosting	<ul style="list-style-type: none">• Push Auto adjust button• Adjust Phase and Clock controls via OSD• Eliminate video extension cables• Perform monitor reset• Lower video resolution or increase font size
Shaky/Jittery Video	Wavy picture or fine movement	<ul style="list-style-type: none">• Push Auto Adjust button• Adjust Phase and Clock controls via OSD• Perform monitor reset• Check environmental factors• Relocate and test in other room
Missing Pixels	LCD screen has spots	<ul style="list-style-type: none">• Cycle power on-off• These are pixels that are permanently off and is a natural defect that occurs in LCD technology
Brightness Problems	Picture too dim or too bright	<ul style="list-style-type: none">• Perform monitor reset• Push Auto Adjust button• Adjust brightness & contrast controls
Geometric Distortion	Screen not centered correctly	<ul style="list-style-type: none">• Perform monitor reset on "Position Settings Only"• Push auto-adjust button• Adjust the centering controls• Ensure monitor is in proper video mode
Horizontal/Vertical Lines	Screen has one or more lines	<ul style="list-style-type: none">• Perform monitor reset• Push Auto Adjust button

		<ul style="list-style-type: none"> • Adjust Phase and Clock controls via OSD • Perform monitor self-test feature check and determine if these lines are also in self-test mode • Check for bent or broken pins
Sync Problems	Screen is scrambled or appears torn	<ul style="list-style-type: none"> • Perform monitor reset • Push Auto Adjust button • Adjust Phase and Clock controls via OSD • Perform monitor self-test feature check to determine if scrambled screen appears in self-test mode • Check for bent or broken pins • Boot up in the "safe mode"
LCD Scratched	Screen has scratches or smudges	<ul style="list-style-type: none"> • Turn monitor off and clean the screen • For cleaning instruction, see Caring for Your Monitor.
Safety Related Issues	Visible signs of smoke or sparks	<ul style="list-style-type: none"> • Do not perform any troubleshooting steps • Monitor needs to be replaced
Intermittent Problems	Monitor malfunctions on & off	<ul style="list-style-type: none"> • Ensure monitor is in proper video mode • Ensure video cable connection to computer and to the flat panel is secure • Perform monitor reset • Perform monitor self-test feature check to determine if the intermittent problem occurs in self-test mode

Product Specific Problems

SPECIFIC SYMPTOMS	WHAT YOU EXPERIENCE	POSSIBLE SOLUTIONS
Screen image is too small	Image is centered on screen, but does not fill entire viewing area	<ul style="list-style-type: none"> • Perform monitor reset on "All Settings"
Cannot adjust the monitor with the buttons on the front panel	OSD does not appear on the screen	<ul style="list-style-type: none"> • Turn the monitor off and unplug the power cord and then plug back and power on

USB Problems

SPECIFIC SYMPTOMS	WHAT YOU EXPERIENCE	POSSIBLE SOLUTIONS
USB interface is not working	USB peripherals are not working	<ul style="list-style-type: none"> • Check that your monitor is powered ON. • Reconnect the upstream cable to your computer. • Reconnect the USB peripherals (downstream connector). • Switch off and then turn on the monitor again.
High Speed USB 2.0 interface is slow.	High Speed USB 2.0 peripherals working slowly or not at all.	<ul style="list-style-type: none"> • Check that your computer is USB 2.0 capable. • Verify USB 2.0 source on your computer. • Reconnect the upstream cable to your computer. • Reconnect the USB peripherals (downstream connector).

Troubleshooting Your Soundbar

COMMON SYMPTOMS	WHAT YOU EXPERIENCE	POSSIBLE SOLUTIONS
No Sound	No power to Soundbar - the power indicator is off. (built-in DC power supply. i.e. 1905FP)	<ul style="list-style-type: none"> • Turn the Power/Volume knob on the Soundbar clockwise to the middle position; check if the power indicator (green LED) on the front of the Soundbar is illuminated. • Confirm that the power cable from the Soundbar is plugged into the monitor. • Confirm that the monitor has power. • If the monitor has no power, see Troubleshooting your monitor for monitor common problem.
No Sound	Soundbar has power - power indicator is on.	<ul style="list-style-type: none"> • Plug the audio line-in cable into the computer's audio out jack. • Set all Windows volume controls to their maximum. • Play some audio content on the computer (i.e. audio CD, or MP3). • Turn the Power/Volume knob on the Soundbar clockwise to a higher volume setting. • Clean and reseal the audio line-in plug. • Test the Soundbar using another audio source (i.e. portable CD player).
Distorted Sound	Computer's sound card is used as the audio source.	<ul style="list-style-type: none"> • Clear any obstructions between the Soundbar and the user. • Confirm that the audio line-in plug is completely inserted into the jack of the sound card. • Set all Windows volume controls to their midpoints. • Decrease the volume of the audio application. • Turn the Power/Volume knob on the Soundbar counter-clockwise to a lower volume setting. • Clean and reseal the audio line-in plug. • Troubleshoot the computer's sound card. • Test the Soundbar using another audio source (i.e. portable CD player).
Distorted Sound	Other audio source is used.	<ul style="list-style-type: none"> • Clear any obstructions between the Soundbar and the user. • Confirm that the audio line-in plug is completely inserted into the jack of the audio source. • Decrease the volume of the audio source. • Turn the Power/Volume knob on the Soundbar counter-clockwise to a lower volume setting. • Clean and reseal the audio line-in plug.
Unbalanced Sound Output	Sound from only one side of Soundbar	<ul style="list-style-type: none"> • Clear any obstructions between the Soundbar and the user. • Confirm that the audio line-in plug is completely inserted into the jack of the sound card or audio source. • Set all Windows audio balance controls (L-R) to their midpoints. • Clean and reseal the audio line-in plug. • Troubleshoot the computer's sound card. • Test the Soundbar using another audio source (i.e. portable CD player).
Low Volume	Volume is too low.	<ul style="list-style-type: none"> • Clear any obstructions between the Soundbar and the user. • Turn the Power/Volume knob on the Soundbar clockwise to the maximum volume setting. • Set all Windows volume controls to their maximum. • Increase the volume of the audio application. • Test the Soundbar using another audio source (i.e. portable CD player).

Appendix

Dell™ 1704FPV Flat Panel Monitor

- [Warranty](#)
 - [Safety Information](#)
 - [Contacting Dell](#)
 - [Regulatory Notices](#)
 - [Recycling](#)
 - [Your Monitor Set-up Guide](#)
-

Warranty

U.S. Terms and Conditions of Sale

These terms and conditions ("Agreement") apply to your purchase of computer systems and/or related products and/or services and support sold in the United States ("Product") by the Dell entity named on the invoice or acknowledgement ("Dell") provided to you. By accepting delivery of the Product, you accept and are bound to the terms and conditions of this Agreement. If you do not wish to be bound by this Agreement, you must notify Dell immediately and return your purchase pursuant to Dell's Total Satisfaction Return Policy. (See: <http://support.dell.com/ContactUs/ByPhone.aspx?c=us&l=en&s=gen> for our contact information.) If returned, Product(s) must remain in the boxes in which they were shipped. THIS AGREEMENT SHALL APPLY UNLESS (I) YOU HAVE A SEPARATE PURCHASE AGREEMENT WITH DELL, IN WHICH CASE THE SEPARATE AGREEMENT SHALL GOVERN; OR (II) OTHER DELL TERMS AND CONDITIONS APPLY TO THE TRANSACTION.

1. Other Documents.

This Agreement may NOT be altered, supplemented, or amended by the use of any other document(s) unless otherwise agreed to in a written agreement signed by both you and Dell. If you do not receive an invoice or acknowledgement in the mail, via e-mail, or with your Product, information about your purchase may be obtained at <http://support.dell.com/dellcare/Invoice.aspx> or by contacting your sales representative.

2. Payment Terms; Orders; Quotes; Interest.

Payment terms are within Dell's sole discretion, and, unless otherwise agreed to by Dell, payment must be made at the time of purchase. Payment for Product may be made by credit card, wire transfer, or some other prearranged payment method. Dell may invoice parts of an order separately. Your order is subject to cancellation by Dell, at Dell's sole discretion. Unless you and Dell have agreed to a different discount, Dell's standard pricing policy for Dell™-branded systems, which include both hardware and services in one discounted price, allocates the discount off list price applicable to the service portion of the system to be equal to the overall calculated percentage discount off list price on the entire system. Dell is not responsible for pricing, typographical, or other errors, in any offer by Dell and reserves the right to cancel any orders resulting from such errors.

3. Shipping Charges; Taxes; Title; Risk of Loss.

Shipping and handling are additional unless otherwise expressly indicated at the time of sale. Loss or damage that occurs during shipping by a carrier selected by Dell is Dell's responsibility. Loss or damage that occurs during shipping by a carrier selected by you is your responsibility. You must notify Dell within 30 days of the date of your invoice or acknowledgement if you believe any part of your purchase is missing, wrong or damaged. Unless you provide Dell with a valid and correct tax exemption certificate applicable to your purchase of Product and the Product ship-to location, you are responsible for sales and other taxes associated with the order. Shipping dates are estimates only. Title to software will remain with the applicable licensor(s).

4. Warranties.

THE LIMITED WARRANTIES APPLICABLE TO DELL-BRANDED HARDWARE PRODUCT CAN BE FOUND AT <http://www.dell.com/policy/legal/warranty.htm> OR IN THE DOCUMENTATION DELL PROVIDES WITH THE PRODUCT. DELL MAKES NO WARRANTIES FOR SERVICE, SOFTWARE, OR NON-DELL BRANDED PRODUCT. SUCH PRODUCT IS PROVIDED BY DELL "AS IS." WARRANTY AND SERVICE FOR NON-DELL BRANDED PRODUCT, IF ANY, IS PROVIDED BY THE ORIGINAL MANUFACTURER, NOT BY DELL. DELL MAKES NO EXPRESS WARRANTIES EXCEPT THOSE STATED IN DELL'S APPLICABLE WARRANTY STATEMENT IN EFFECT ON THE DATE OF THE INVOICE, PACKING SLIP OR ACKNOWLEDGEMENT. WARRANTIES AND SERVICE WILL BE EFFECTIVE, AND DELL WILL BE OBLIGATED TO HONOR ANY SUCH WARRANTIES AND SERVICES, ONLY UPON DELL'S RECEIPT OF PAYMENT IN FULL FOR THE ITEM TO BE WARRANTED OR SERVICED.

5. Software.

All software is provided subject to the license agreement that is part of the software package and you agree that you will be bound by such license agreement.

6. Return Policies; Exchanges.

New and refurbished Product that you purchase directly from Dell (and not a third party) you may return or exchange only in accordance with Dell's return policy in effect on the date of the invoice or acknowledgement. Any returns or exchanges will be made in accordance with Dell's exchange policies in effect on the date of the return or exchange. You

must contact us directly before you attempt to return Product to obtain a Return Material Authorization Number for you to include with your return. You must return Product to us in their original or equivalent packaging. You are responsible for risk of loss, shipping and handling fees for returning or exchanging Product. Additional fees may apply. Dell's return policy for Dell-branded Product can be found at: <http://www.dell.com/policy/legal/warranty.htm>. Non-Dell branded software and peripheral return policies can be found at: http://rcommerce.us.dell.com/rcomm/include/dw_policies.htm.

Refurbished Product return policies can be found at: http://www.dell.com/us/en/dfh/topics/segtopic_nav_info_002_info.htm. If you fail to follow the return or exchange instructions and policies provided by Dell, Dell is not responsible whatsoever for Product that is lost, damaged, modified or otherwise processed for disposal or resale. If you are returning all components in an order, you will be credited the full amount paid for the order. At Dell's discretion, credit for partial returns may be less than invoice or individual component prices due to bundled or promotional pricing.

7. **Changed or Discontinued Product.**

Dell's policy is one of ongoing update and revision. Dell may revise and discontinue Product at any time without notice to you and this may affect information saved in your online "cart." Dell will ship Product that has the functionality and performance of the Product ordered, but changes between what is shipped and what is described in a specification sheet or catalog are possible. Parts used in repairing or servicing Product may be new, equivalent-to-new, or reconditioned.

8. **Service and Support.**

Service offerings may vary from Product to Product. If you purchase optional services and support from Dell, Dell and/or your third-party service provider will provide such service and support to you in the United States in accordance with the terms and conditions located at http://www.dell.com/us/en/gen/services/service_service_contracts.htm or as mailed to you. You may contact Dell for more information, see <http://www1.us.dell.com/content/topics/segtopic.aspx/contact/contact?c=us&l=en&s=gen> for contact information. Dell and/or the third-party service provider may at their discretion, revise their general and optional service and support programs and the terms and conditions that govern them without prior notice to you. Dell has no obligation to provide service or support until Dell has received full payment for the Product or service/support contract you purchased. Dell is not obligated to provide service or support you purchase through a third party and not Dell.

9. **Limitation of Liability.**

DELL DOES NOT ACCEPT LIABILITY BEYOND THE REMEDIES SET FORTH HEREIN, INCLUDING BUT NOT LIMITED TO ANY LIABILITY FOR PRODUCT NOT BEING AVAILABLE FOR USE, LOST PROFITS, LOSS OF BUSINESS OR FOR LOST OR CORRUPTED DATA OR SOFTWARE, OR THE PROVISION OF SERVICES AND SUPPORT. EXCEPT AS EXPRESSLY PROVIDED HEREIN, DELL WILL NOT BE LIABLE FOR ANY CONSEQUENTIAL, SPECIAL, INDIRECT, OR PUNITIVE DAMAGES, EVEN IF ADVISED OF THE POSSIBILITY OF SUCH DAMAGES, OR FOR ANY CLAIM BY ANY THIRD PARTY. YOU AGREE THAT FOR ANY LIABILITY RELATED TO THE PURCHASE OF PRODUCT, DELL IS NOT LIABLE OR RESPONSIBLE FOR ANY AMOUNT OF DAMAGES ABOVE THE AMOUNT INVOICED FOR THE APPLICABLE PRODUCT. NOTWITHSTANDING ANYTHING IN THIS AGREEMENT TO THE CONTRARY, THE REMEDIES SET FORTH IN THIS AGREEMENT SHALL APPLY EVEN IF SUCH REMEDIES FAIL THEIR ESSENTIAL PURPOSE. **DELL IS NOT LIABLE TO YOU FOR WARRANTIES, SUPPORT, OR SERVICE MADE BY OR PURCHASED FROM A THIRD PARTY AND NOT DIRECTLY FROM DELL. DELL IS NOT RESPONSIBLE FOR REPRESENTATIONS OR OMISSIONS MADE BY A THIRD PARTY.**

10. **Applicable Law; Not For Resale or Export.**

You agree to comply with all applicable laws and regulations of the various states and of the United States. You agree and represent that you are buying only for your own internal use only, and not for resale or export. Dell has separate terms and conditions governing resale of Product by third parties and transactions outside the United States. Terms and conditions for resale are located at: <http://www.dell.com/policy/legal/termsofsale.htm>.

11. **Governing Law.**

THIS AGREEMENT AND ANY SALES THERE UNDER SHALL BE GOVERNED BY THE LAWS OF THE STATE OF TEXAS, WITHOUT REGARD TO CONFLICTS OF LAWS RULES.

12. **Headings.**

The section headings used herein are for convenience of reference only and do not form a part of these terms and conditions, and no construction or inference shall be derived there from.

13. **Binding Arbitration.**

ANY CLAIM, DISPUTE, OR CONTROVERSY (WHETHER IN CONTRACT, TORT, OR OTHERWISE, WHETHER PREEXISTING, PRESENT OR FUTURE, AND INCLUDING STATUTORY, COMMON LAW, INTENTIONAL TORT AND EQUITABLE CLAIMS) BETWEEN CUSTOMER AND DELL, its agents, employees, principals, successors, assigns, affiliates (collectively for purposes of this paragraph, "Dell") arising from or relating to this Agreement, its interpretation, or the breach, termination or validity thereof, the relationships which result from this Agreement (including, to the full extent permitted by applicable law, relationships with third parties who are not signatories to this Agreement), Dell's advertising, or any related purchase SHALL BE RESOLVED EXCLUSIVELY AND FINALLY BY BINDING ARBITRATION ADMINISTERED BY THE NATIONAL ARBITRATION FORUM (NAF) under its Code of Procedure then in effect (available via the Internet at <http://www.arb-forum.com> , or via telephone at 1-800-474-2371). The arbitration will be limited solely to the dispute or controversy between customer and Dell. NEITHER CUSTOMER NOR DELL SHALL BE ENTITLED TO JOIN OR CONSOLIDATE CLAIMS BY OR AGAINST OTHER CUSTOMERS, OR ARBITRATE ANY CLAIM AS A REPRESENTATIVE OR CLASS ACTION OR IN A PRIVATE ATTORNEY GENERAL CAPACITY. This transaction involves interstate commerce, and this provision shall be governed by the Federal Arbitration Act 9 U.S.C. sec. 1-16 (FAA). Any award of the arbitrator(s) shall be final and binding on each of the parties, and may be entered as a judgment in any court of competent jurisdiction. Dell will be responsible for paying any arbitration filing fees and fees required to obtain a hearing to the extent such fees exceed the amount of the filing fee for initiating a claim in the court of general jurisdiction in the state in which you reside. Each party shall pay for its own costs and attorneys' fees, if any. However, if any party prevails on a statutory claim that affords the prevailing party attorneys' fees, or if there is a written agreement providing for fees, the Arbitrator may award reasonable fees to the prevailing party, under the standards for fee shifting provided by law. Information may be obtained and claims may be filed with the NAF at P.O. Box 50191, Minneapolis, MN 55405. (REV 4/04)

Limited Warranty for Dell-Branded Hardware Products (U.S. Only)

Dell-branded hardware products purchased in the U.S. come with either a 90-day, 1-year, 2-year, 3-year, or 4-year limited warranty depending on the product purchased. To determine which warranty came with your hardware product(s), see your packing slip or invoice.

What is covered by this limited warranty?

This limited warranty covers defects in materials and workmanship in your—our end-user customer's—Dell-branded hardware products, including Dell-branded peripheral products.

What is not covered by this limited warranty?

This limited warranty does not cover:

- Software, including the operating system and software added to the Dell-branded hardware products through our factory-integration system, third-party software, or the reloading of software
- Non-Dell-branded and Solution Provider Direct products and accessories
- Problems that result from:
 - External causes such as accident, abuse, misuse, or problems with electrical power
 - Servicing not authorized by Dell
 - Usage that is not in accordance with product instructions
 - Failure to follow the product instructions or failure to perform preventive maintenance
 - Problems caused by using accessories, parts, or components not supplied by Dell
- Products with missing or altered Service Tags or serial numbers
- Products for which Dell has not received payment

THIS WARRANTY GIVES YOU SPECIFIC LEGAL RIGHTS, AND YOU MAY ALSO HAVE OTHER RIGHTS WHICH VARY FROM STATE TO STATE (OR JURISDICTION TO JURISDICTION). DELL'S RESPONSIBILITY FOR MALFUNCTIONS AND DEFECTS IN HARDWARE IS LIMITED TO REPAIR AND REPLACEMENT AS SET FORTH IN THIS WARRANTY STATEMENT. ALL EXPRESS AND IMPLIED WARRANTIES FOR THE PRODUCT, INCLUDING BUT NOT LIMITED TO ANY IMPLIED WARRANTIES AND CONDITIONS OF MERCHANTABILITY AND FITNESS FOR A PARTICULAR PURPOSE, ARE LIMITED IN TIME TO THE TERM OF THE LIMITED WARRANTY PERIOD REFLECTED ON YOUR PACKING SLIP OR INVOICE. NO WARRANTIES, WHETHER EXPRESS OR IMPLIED, WILL APPLY AFTER THE LIMITED WARRANTY PERIOD HAS EXPIRED. SOME STATES DO NOT ALLOW LIMITATIONS ON HOW LONG AN IMPLIED WARRANTY LASTS, SO THIS LIMITATION MAY NOT APPLY TO YOU.

WE DO NOT ACCEPT LIABILITY BEYOND THE REMEDIES PROVIDED FOR IN THIS LIMITED WARRANTY OR FOR CONSEQUENTIAL OR INCIDENTAL DAMAGES, INCLUDING, WITHOUT LIMITATION, ANY LIABILITY FOR THIRD-PARTY CLAIMS AGAINST YOU FOR DAMAGES, FOR PRODUCTS NOT BEING AVAILABLE FOR USE, OR FOR LOST DATA OR LOST SOFTWARE. OUR LIABILITY WILL BE NO MORE THAN THE AMOUNT YOU PAID FOR THE PRODUCT THAT IS THE SUBJECT OF A CLAIM. THIS IS THE MAXIMUM AMOUNT FOR WHICH WE ARE RESPONSIBLE.

SOME STATES DO NOT ALLOW THE EXCLUSION OR LIMITATION OF INCIDENTAL OR CONSEQUENTIAL DAMAGES, SO THE ABOVE LIMITATION OR EXCLUSION MAY NOT APPLY TO YOU.

How long does this limited warranty last?

This limited warranty lasts for the time period indicated on your packing slip or invoice, except for the following Dell-branded hardware:

- Portable computer batteries carry a 1-year limited warranty.
- Projector lamps carry a 90-day limited warranty.
- Memory carries a lifetime limited warranty.
- Monitors carry the longer of either a 3-year limited warranty or the remainder of the warranty for the Dell™ computer to which the monitor will be connected.
- PDAs, MP3 players, earphones, remote inline controls, and AC adapters carry a 1-year limited warranty.
- Other add-on hardware carries the longer of either a 1-year limited warranty for new parts and a 90-day limited warranty for reconditioned parts or, for both new and reconditioned parts, the remainder of the warranty for the Dell computer on which such parts are installed.

The limited warranty on all Dell-branded products begins on the date of the packing slip or invoice. The warranty period is not extended if we repair or replace a warranted product or any parts. Dell may change the availability of limited warranties, at its discretion, but any changes will not be retroactive.

What do I do if I need warranty service?

Before the warranty expires, please call us at the relevant number listed in the following table. Please also have your Dell Service Tag or order number available.

Web Support	support.dell.com/ContactUs/ContactUsHome.aspx?c=us&l=en&s=gen
Individual Home Consumers:	U.S. Only
Technical Support	1-800-624-9896
Customer Service	1-800-624-9897
Individual Home Consumers who purchased through an Employee Purchase Program:	
Technical Support and Customer Service	1-800-822-8965
Home and Small Business Commercial Customers:	
Technical Support and Customer Service	1-800-456-3355
Medium, Large, or Global Commercial Customers, Healthcare Customers, and Value-Added Resellers (VARs):	
Technical Support and Customer Service	1-800-822-8965
Government and Education Customers:	
Technical Support and Customer Service	1-800-234-1490
Dell-Branded Memory	1-888-363-5150

What will Dell do?

During the 90 days of the 90-day limited warranty and the first year of all other limited warranties: During the 90 days of the 90-day limited warranty and the first year of all other limited warranties, we will repair any Dell-branded hardware products returned to us that prove to be defective in materials or workmanship. If we are not able to repair the product, we will replace it with a comparable product that is new or refurbished.

When you contact us, we will issue a Return Material Authorization Number for you to include with your return. You must return the products to us in their original or equivalent packaging, prepay shipping charges, and insure the shipment or accept the risk if the product is lost or damaged in shipment. We will return the repaired or replacement products to you. We will pay to ship the repaired or replaced products to you if you use an address in the United States (excluding Puerto Rico and U.S. possessions and territories). Otherwise, we will ship the product to you freight collect.

If we determine that the product is not covered under this warranty, we will notify you and inform you of service alternatives that are available to you on a fee basis.

NOTE: Before you ship the product(s) to us, make sure to back up the data on the hard drive(s) and any other storage device(s) in the product(s). Remove any confidential, proprietary, or personal information and removable media such as floppy disks, CDs, or PC Cards. We are not responsible for any of your confidential, proprietary, or personal information; lost or corrupted data; or damaged or lost removable media.

During the remaining years: For the remaining period of the limited warranty, we will replace any defective part with new or refurbished parts, if we agree that it needs to be replaced. When you contact us, we will require a valid credit card number at the time you request a replacement part, but we will not charge you for the replacement part as long as you return the original part to us within 30 days after we ship the replacement part to you. If we do not receive the original part within 30 days, we will charge to your credit card the then-current standard price for that part.

We will pay to ship the part to you if you use an address in the United States (excluding Puerto Rico and U.S. possessions and territories). Otherwise, we will ship the part freight collect. We will also include a prepaid shipping container with each replacement part for your use in returning the replaced part to us.

NOTE: Before you replace parts, make sure to back up the data on the hard drive(s) and any other storage device(s) in the product(s). We are not responsible for lost or corrupted data.

What if I purchased a service contract?

If your service contract is with Dell, service will be provided to you under the terms of the service agreement. Please refer to that contract for details on how to obtain service.

If you purchased through us a service contract with one of our third-party service providers, please refer to that contract for details on how to obtain service.

How will you fix my product?

We use new and refurbished parts made by various manufacturers in performing warranty repairs and in building replacement parts and systems. Refurbished parts and systems are parts or systems that have been returned to Dell, some of which were never used by a customer. All parts and systems are inspected and tested for quality. Replacement parts and systems are covered for the remaining period of the limited warranty for the product you bought. Dell owns all parts removed from repaired products.

May I transfer the limited warranty?

Limited warranties on systems may be transferred if the current owner transfers ownership of the system and records the transfer with us. The limited warranty on Dell-branded memory may not be transferred. You may record your transfer by going to Dell's website:

- If you are an Individual Home Consumer, go to www.dell.com/us/en/dhs/topics/sbtopic_015_ccare.htm
- If you are a Home Office, Small, Medium, Large, or Global Commercial Customer, go to www.dell.com/us/en/biz/topics/sbtopic_ccare_nav_015_ccare.htm
- If you are a Government, Education, or Healthcare Customer, or an Individual Home Consumer who purchased through an Employee Purchase Program, go to www.dell.com/us/en/pub/topics/sbtopic_015_ccare.htm

If you do not have Internet access, call your customer care representative or call 1-800-624-9897.

All requests to transfer ownership are at Dell's sole discretion. All such transfers will be subject to the terms and conditions of the original service or limited warranty agreement and Dell's terms and conditions of sale located at www.dell.com. Dell cannot guarantee the authenticity of the products, limited warranties, service or support, or the accuracy of the listings of products you purchase from a third party.

Total Satisfaction Return Policy (U.S. Only)

We value our relationship with you and want to make sure that you are satisfied with your purchases. That is why we offer a Total Satisfaction return policy for most products that you, the end-user customer, purchase directly from Dell. Under this policy, you may return to Dell products that you purchased directly from Dell for a credit or a refund of the purchase price paid, less shipping and handling and applicable return fees as follows:

New Hardware Products and Accessories — Unless you have a separate agreement with Dell, all hardware, accessories, peripherals, parts, and unopened software still in its/their sealed package, excluding the products listed below, may be returned within twenty-one (21) days from the date on the packing slip or invoice.

Exclusions from the foregoing return policy:

- New Dell PowerEdge™, Dell PowerConnect™, and Dell PowerVault™ products (excluding PowerVault 160T tape libraries) may be returned within thirty (30) days from the date on the packing slip or invoice, except that new PowerEdge **SC** servers and n series products purchased from the Small and Medium Business Sales Division may only be returned within fourteen (14) days from the date on the packing slip or invoice.
- Application software or an operating system that has been installed by Dell may not be returned unless you return the entire computer under the 21-day return policy, if applicable to your purchase (if not applicable to your purchase, you may not return application software or an operating system).
- Nondefective third-party and Dell-branded software, peripheral, electronics and accessory products (for example: televisions, printers, projectors, MP3 players, PDAs, battery chargers, un-preinstalled third-party software, wireless cards/access points/routers), including but not limited to those sold by or through Dell's "Software & Peripherals" or "Electronics & Accessories" groups, may be returned within twenty-one (21) days from the date on the packing slip or invoice, but a fifteen percent (15%) return fee may be deducted from any refund or credit.
- Dell | EMC storage products, EMC-branded products, Unisys-branded products, PowerVault 160T tape libraries, enterprise software, non-Dell-branded enterprise products, software and/or software licenses, or any non-Dell-customized hardware and/or software product(s) may not be returned at any time.

Reconditioned or Refurbished Dell-Branded Hardware Products and Parts — All reconditioned or refurbished PowerEdge, PowerConnect, and PowerVault products may be returned within thirty (30) days from the date on the packing slip or invoice. All other reconditioned or refurbished Dell-branded hardware products and parts may be returned within fourteen (14) days of the date on the packing slip or invoice.

How to Return — To return products, e-mail or call Dell customer service to receive a Credit Return Authorization Number within the return policy period applicable to the product you want to return. You must obtain a Credit Return Authorization Number in order to return the product. See "Contacting Dell" or "Getting Help" in your customer documentation (or go to www.dell.com/us/en/gen/contact.htm) to find the appropriate contact information for obtaining customer assistance.

You must ship the products to Dell within five (5) days of the date that Dell issues the Credit Return Authorization Number. You must also return the products to Dell in their original packaging, in as-new condition along with any media, documentation, and all other items that were included in the original shipment, prepay shipping charges, and insure the shipment or accept the risk of loss or damage during shipment.

NOTE: Before you ship the product(s) to us, make sure to back up the data on the hard drive(s) and any other storage device(s) in the product(s). Remove any confidential, proprietary, or personal information and removable media such as floppy disks, CDs, or PC Cards. We are not responsible for any of your confidential, proprietary, or personal information; lost or corrupted data; or damaged or lost removable media.

Limited Warranty Terms for Dell-Branded Hardware Products (Canada Only)

Dell-branded hardware products purchased in Canada come with either a 90-day, 1-year, 2-year, 3-year, or 4-year limited warranty depending on the product purchased. To determine which warranty came with your hardware product(s), see your packing slip or invoice.

What is covered by this limited warranty?

This limited warranty covers defects in materials and workmanship in your—our end-user customer's—Dell-branded hardware products, including Dell-branded peripheral products.

What is not covered by this limited warranty?

This limited warranty does not cover:

- Software, including the operating system and software added to the Dell-branded hardware products through our factory-integration system, or the reloading of the software
- Non–Dell-branded and Solution Provider Direct products and accessories
- Problems that result from:
 - External causes such as accident, abuse, misuse, or problems with electrical power
 - Servicing not authorized by Dell
 - Usage that is not in accordance with product instructions
 - Failure to follow the product instructions or failure to perform preventive maintenance
 - Problems caused by using accessories, parts, or components not supplied by Dell
- Products with missing or altered Service Tags or serial numbers
- Products for which Dell has not received payment

THIS WARRANTY GIVES YOU SPECIFIC LEGAL RIGHTS, AND YOU MAY ALSO HAVE OTHER RIGHTS WHICH VARY FROM PROVINCE TO PROVINCE. DELL'S RESPONSIBILITY FOR MALFUNCTIONS AND DEFECTS IN PRODUCT IS LIMITED TO REPAIR AND REPLACEMENT AS SET FORTH IN THIS WARRANTY STATEMENT, FOR THE TERM OF THE WARRANTY PERIOD REFLECTED ON YOUR PACKING SLIP OR INVOICE. EXCEPT FOR THE EXPRESS WARRANTIES CONTAINED IN THIS WARRANTY STATEMENT, DELL DISCLAIMS ALL OTHER WARRANTIES AND CONDITIONS, EXPRESS OR IMPLIED, INCLUDING WITHOUT LIMITATION IMPLIED WARRANTIES AND CONDITIONS OF MERCHANTABILITY AND FITNESS FOR A PARTICULAR PURPOSE, STATUTORY OR OTHERWISE. SOME PROVINCES DO NOT ALLOW THE EXCLUSION OF CERTAIN IMPLIED WARRANTIES OR CONDITIONS, OR LIMITATIONS ON HOW LONG AN IMPLIED WARRANTY OR CONDITION LASTS. THEREFORE, THE FOREGOING EXCLUSIONS AND LIMITATIONS MAY NOT APPLY TO YOU.

WE DO NOT ACCEPT LIABILITY BEYOND THE REMEDIES PROVIDED FOR IN THIS WARRANTY STATEMENT OR FOR SPECIAL, INDIRECT, CONSEQUENTIAL, OR INCIDENTAL DAMAGES, INCLUDING, WITHOUT LIMITATION, ANY LIABILITY FOR THIRD-PARTY CLAIMS AGAINST YOU FOR DAMAGES, FOR PRODUCTS NOT BEING AVAILABLE FOR USE, OR FOR LOST DATA OR LOST SOFTWARE. OUR LIABILITY WILL BE NO MORE THAN THE AMOUNT YOU PAID FOR THE PRODUCT THAT IS THE SUBJECT OF A CLAIM. THIS IS THE MAXIMUM AMOUNT FOR WHICH WE ARE RESPONSIBLE.

SOME PROVINCES DO NOT ALLOW THE EXCLUSION OR LIMITATION OF SPECIAL, INDIRECT, INCIDENTAL, OR CONSEQUENTIAL DAMAGES, SO THE ABOVE LIMITATION OR EXCLUSION MAY NOT APPLY TO YOU.

How long does this limited warranty last?

This limited warranty lasts for the time period indicated on your packing slip or invoice, except that the limited warranty on Dell-branded batteries lasts only 1 year and the limited warranty on the lamps for Dell-branded projectors lasts only 90 days. The limited warranty begins on the date of the packing slip or invoice. The warranty period is not extended if we repair or replace a warranted product or any parts. Dell may change the terms and availability of limited warranties, at its discretion, but any changes will not be retroactive (that is, the warranty terms in place at the time of purchase will apply to your purchase).

What do I do if I need warranty service?

Before the warranty expires, please call us at the relevant number listed in the following table. Please also have your Dell Service Tag or order number available.

Web Support	support.dell.com/ContactUs/ContactUsHome.aspx?c=us&l=en&s=gen
Individual Home Consumers; Home Office and Small Business Customers:	Canada Only
Technical Support and Customer Service	1-800-847-4096
Medium, Large, and Global Commercial Customers; Government, Education, and Healthcare Customers; and Value-Added Resellers (VARs):	
Technical Support	1-800-387-5757
Customer Service	1-800-326-9463
Government or Education Customers, or Individual Home Consumers who purchased through an Employee Purchase Program:	

Technical Support	1-800-387-5757
Customer Service	1-800-326-9463 (Extension 8221 for Individual Consumers)
Dell-Branded Memory	1-888-363-5150

What will Dell do?

During the 90 days of the 90-day limited warranty and the first year of all other limited warranties: During the 90 days of the 90-day limited warranty and the first year of all other limited warranties, we will repair any Dell-branded hardware products returned to us that prove to be defective in materials or workmanship. If we are not able to repair the product, we will replace it with a comparable product that is new or refurbished.

When you contact us, we will issue a Return Material Authorization Number for you to include with your return. You must return the products to us in their original or equivalent packaging, prepay shipping charges, and insure the shipment or accept the risk if the product is lost or damaged in shipment. We will return the repaired or replacement products to you. We will pay to ship the repaired or replaced products to you if you use an address in Canada. Otherwise, we will ship the product to you freight collect.

If we determine that the problem is not covered under this warranty, we will notify you and inform you of service alternatives that are available to you on a fee basis.

NOTE: Before you ship the product(s) to us, make sure to back up the data on the hard drive(s) and any other storage device(s) in the product(s). Remove any confidential, proprietary, or personal information and removable media such as floppy disks, CDs, or PC Cards. We are not responsible for any of your confidential, proprietary, or personal information; lost or corrupted data; or damaged or lost removable media.

During the remaining years following the first year of all limited warranties: We will replace any defective part with new or refurbished parts, if we agree that it needs to be replaced. When you contact us, we will require a valid credit card number at the time you request a replacement part, but we will not charge you for the replacement part as long as you return the original part to us within 30 days after we ship the replacement part to you. If we do not receive the original part within 30 days, we will charge to your credit card the then-current standard price for that part.

We will pay to ship the part to you if you use an address in Canada. Otherwise, we will ship the part freight collect. We will also include a prepaid shipping container with each replacement part for your use in returning the replaced part to us.

NOTE: Before you replace parts, make sure to back up the data on the hard drive(s) and any other storage device(s) in the product(s). We are not responsible for lost or corrupted data.

What if I purchased a service contract?

If your service contract is with Dell, service will be provided to you under the terms of the service contract. Please refer to that contract for details on how to obtain service. Dell's service contracts can be found online at www.dell.ca or by calling Customer Care at 1-800-847-4096. If you purchased through us a service contract with one of our third-party service providers, please refer to that contract (mailed to you with your packing slip or invoice) for details on how to obtain service.

How will you fix my product?

We use new and refurbished parts made by various manufacturers in performing warranty repairs and in building replacement parts and systems. Refurbished parts and systems are parts or systems that have been returned to Dell, some of which were never used by a customer. All parts and systems are inspected and tested for quality. Replacement parts and systems are covered for the remaining period of the limited warranty for the product you bought. Dell owns all parts removed from repaired products.

May I transfer the limited warranty?

Limited warranties on systems may be transferred if the current owner transfers ownership of the system and records the transfer with us. The limited warranty on Dell-branded memory may not be transferred. You may record your transfer by going to Dell's website.

- For Canada-purchased computers (in-country transfers) and to transfer from one customer to another, go to www.dell.ca/ca/en/gen/topics/segtopic_ccare_nav_013_ccare.htm
- For out-of-country transfers (outside of the original country of purchase), go to www.dell.com/us/en/biz/topics/sbtopic_ccare_nav_016_ccare.htm

If you do not have Internet access, call Dell at 1-800-847-4096 (Home Consumer customers) or 1-800-326-9463 (Corporate Commercial or Government customers).

All requests to transfer ownership are at Dell's sole discretion. All such transfers will be subject to the terms and conditions of the original service or limited warranty agreement and Dell's terms and conditions of sale located at www.dell.com. Dell cannot guarantee the authenticity of the products, limited warranties, service or support, or the accuracy of the listings of products you purchase from a third party.

Total Satisfaction Return Policy (Canada Only)

If you are an end-user customer who bought new products directly from Dell, you may return them to Dell up to 30 days after you receive them for a refund or credit of the product purchase price. If you are an end-user customer who bought reconditioned or refurbished products from Dell, you may return them to Dell within 14 days after the date on the packing slip or invoice for a refund or credit of the product purchase price. In either case, the refund or credit will not include any shipping and handling charges shown on your packing slip or invoice and will be subject to a fifteen percent (15%) restocking fee, unless

otherwise prohibited by law. If you are an organization that bought the products under a written agreement with Dell, the agreement may contain different terms for the return of products than specified by this policy.

To return products, you must call Dell Customer Service at 1-800-847-4096 to receive a Credit Return Authorization Number. To expedite the process of your refund or credit, Dell expects you to return the products to Dell in their original packaging within 5 days of the date that Dell issues the Credit Return Authorization Number. You must also prepay shipping charges and insure the shipment or accept the risk of loss or damage during shipment. You may return software for a refund or credit only if the sealed package containing the diskette(s) or CD(s) is unopened. Returned products must be in as-new condition, and all of the manuals, diskette(s), CD(s), power cables, and other items included with a product must be returned with it. For customers who want to return, for refund or credit only, either application or operating system software that has been installed by Dell, the whole system must be returned, along with any media and documentation that may have been included in the original shipment.

The "Total Satisfaction" Return Policy does not apply to Dell | EMC storage products. It also does not apply to products purchased through Dell's Software and Peripherals division. For those products, please instead refer to Dell's Software and Peripheral's then-current return policy (see the following section, "Dell Software and Peripherals [Canada Only]").

Dell™ Software and Peripherals (Canada Only)

Third-Party Software and Peripherals Products

Similar to other resellers of software and peripherals, Dell does not warrant third-party products. Third-party software and peripheral products are covered by the warranties provided by the original manufacturer or publisher only. Third-party manufacturer warranties vary from product to product. Consult your product documentation for specific warranty information. More information may also be available from the manufacturer or publisher.

While Dell offers a wide selection of software and peripheral products, we do not specifically test or guarantee that all of the products we offer work with any or all of the various models of Dell computers, nor do we test or guarantee all of the products we sell on the hundreds of different brands of computers available today. If you have questions about compatibility, we recommend and encourage you to contact the third-party software and peripheral product manufacturer or publisher directly.

Dell-Branded Peripheral Products

Dell does provide a limited warranty for new Dell-branded peripheral products (products for which Dell is listed as the manufacturer) such as monitors, batteries, memory, docking stations, and projectors. To determine which limited warranty applies to the product you purchased, see the Dell packing slip or invoice and/or the product documentation that accompanied your product. Descriptions of Dell's limited warranties are described in preceding sections.

1-Year End-User Manufacturer Guarantee (Latin America and the Caribbean Only)

Guarantee

Dell Inc. ("Dell") warrants to the end user in accordance with the following provisions that its branded hardware products, purchased by the end user from a Dell company or an authorized Dell distributor in Latin America or the Caribbean, will be free from defects in materials, workmanship, and design affecting normal use, for a period of 1 year from the original purchase date. Products for which proper claims are made will, at Dell's option, be repaired or replaced at Dell's expense. Dell owns all parts removed from repaired products. Dell uses new and reconditioned parts made by various manufacturers in performing repairs and building replacement products.

Exclusions

This Guarantee does not apply to defects resulting from: improper or inadequate installation, use, or maintenance; actions or modifications by unauthorized third parties or the end user; accidental or willful damage; or normal wear and tear.

Making a Claim

Claims must be made in Latin America or the Caribbean by contacting the Dell point of sale within the guarantee period. The end user must always supply proof of purchase, indicating name and address of the seller, date of purchase, model and serial number, name and address of the customer, and details of symptoms and configuration at the time of malfunction, including peripherals and software used. Otherwise, Dell may refuse the guarantee claim. Upon diagnosis of a warranted defect, Dell will make arrangements and pay for ground freight and insurance to and from Dell's repair/replacement center. The end user must ensure that the defective product is available for collection properly packed in original or equally protective packaging together with the details listed above and the return number provided to the end user by Dell.

Limitation and Statutory Rights

Dell makes no other warranty, guarantee or like statement other than as explicitly stated above, and this Guarantee is given in place of all other guarantees whatsoever, to the fullest extent permitted by law. In the absence of applicable legislation, this Guarantee will be the end user's sole and exclusive remedy against Dell or any of its affiliates, and neither Dell nor any of its affiliates shall be liable for loss of

profit or contracts, or any other indirect or consequential loss arising from negligence, breach of contract, or howsoever.

This Guarantee does not impair or affect mandatory statutory rights of the end user against and/or any rights resulting from other contracts concluded by the end user with Dell and/or any other seller.

Dell World Trade LP

One Dell Way, Round Rock, TX 78682, USA

Dell Computadores do Brasil Ltda (CNPJ No. 72.381.189/0001-10)

Avenida Industrial Belgraf, 400
92990-000 - Eldorado do Sul – RS - Brasil

Dell Computer de Chile Ltda

Coyancura 2283, Piso 3- Of.302,
Providencia, Santiago - Chile

Dell Computer de Colombia Corporation

Carrera 7 #115-33 Oficina 603
Bogota, Colombia

Dell Computer de Mexico SA de CV

Paseo de la Reforma 2620 - 11° Piso
Col. Lomas Altas
11950 México, D.F.

Safety Information

⚠ CAUTION: Use of controls, adjustments, or procedures other than those specified in this documentation may result in exposure to shock, electrical hazards, and/or mechanical hazards.

Read and follow these instructions when connecting and using your computer monitor:

- To help avoid damaging your computer, be sure that the voltage selection switch on the power supply for the computer is set to match the alternating current (AC) power available at your location:
 - 115 volts (V)/60 hertz (Hz) in most of North and South America and some Far Eastern countries such as Japan, South Korea (also 220 volts (V)/60 hertz (Hz)), and Taiwan.
 - 230 volts (V)/50 hertz (Hz) in most of Europe, the Middle East, and the Far East.
- Always be sure that your monitor is electrically rated to operate with the AC power available in your location.

NOTE: This monitor does not need or have a voltage selection switch for setting the AC voltage input. It will automatically accept any AC input voltage according to the ranges defined in the "Electrical Specifications" section.

- Do not store or use the LCD monitor in locations that are exposed to heat, direct sunlight, or extreme cold.
- Avoid moving the LCD monitor between locations with large temperature differences.
- Do not subject the LCD monitor to severe vibration or high impact conditions. For example, do not place the LCD monitor inside a car trunk.
- Do not store or use the LCD monitor in locations exposed to high humidity or dusty environment.
- Do not allow water or other liquids to spill on or into the LCD monitor.
- Keep flat panel monitor in room temperature conditions. Excessive cold or hot conditions can have an adverse effect on the liquid crystal of the display.
- Never insert anything metallic into the monitor openings. Doing so may create the danger of electric shock.
- To avoid electric shock, never touch the inside of the monitor. Only a qualified technician should open the monitor case.
- Never use your monitor if the power cable has been damaged. Do not allow anything to rest on the power cable. Keep the power cable away from where people could trip over it.
- Be sure to grasp the plug, not the cable, when disconnecting the monitor from an electric socket.
- Openings in the monitor cabinet are provided for ventilation. To prevent overheating, these openings should not be blocked or covered. Avoid using the monitor on a bed, sofa, rug, or other soft surface, as doing so may block the ventilation openings in the bottom of the cabinet. If you place the monitor in a bookcase or an enclosed space, be sure to provide adequate ventilation and air flow.
- Place your monitor in a location with low humidity and minimum dust. Avoid places similar to a damp basement or dusty hallway.
- Do not expose the monitor to rain or use it near water (in kitchens, next to swimming pools, etc.). If the monitor accidentally gets wet, unplug it and contact an authorized dealer immediately. You can clean the monitor with a damp cloth when necessary, being sure to unplug the monitor first.
- Place the monitor on a solid surface and treat it carefully. The screen is made of glass and can be damaged if dropped or hit sharply.
- Locate your monitor near an easily accessible electric outlet.
- If your monitor does not operate normally - in particular, if there are any unusual sounds or smells coming from it - unplug it immediately and contact an authorized dealer or service center.
- Do not attempt to remove the back cover, as you will be exposed to an electrical shock hazard. The back cover should only be removed by qualified service personnel.
- High temperatures can cause problems. Don't use your monitor in direct sunlight, and keep it away from heaters, stoves, fireplaces, and other sources of heat.
- Unplug the monitor when it is going to be left unused for an extended period of time.
- Unplug your monitor from the electric outlet before any service is performed.
- Hg Lamp(s) inside this product contains mercury and must be recycled or disposed of according to local, state or federal laws. Or contact the electronic industries alliance: <http://www.eiae.org> for more information.

Contacting Dell

To contact Dell electronically, you can access the following websites:

- www.dell.com
- support.dell.com (technical support)
- premiersupport.dell.com (technical support for educational, government, healthcare, and medium/large business customers, including Premier, Platinum, and Gold customers)

For specific web addresses for your country, find the appropriate country section in the table below.

 **NOTE: Toll-free numbers are for use within the country for which they are listed.**

When you need to contact Dell, use the electronic addresses, telephone numbers, and codes provided in the following table. If you need assistance in determining which codes to use, contact a local or an international operator.

Country (City) International Access Code Country Code City Code	Department Name or Service Area, Website and E-Mail Address	Area Codes, Local Numbers, and Toll-Free Numbers
Anguilla	General Support	toll-free: 800-335-0031
Antigua and Barbuda	General Support	1-800-805-5924
Argentina (Buenos Aires) International Access Code: 00 Country Code: 54 City Code: 11	Website: www.dell.com.ar	
	E-mail: us_latin_services@dell.com	
	E-mail for desktop and portable computers: la-techsupport@dell.com	
	E-mail for servers and EMC: la_enterprise@dell.com	
	Customer Care	toll-free: 0-800-444-0730
	Tech Support	toll-free: 0-800-444-0733
	Tech Support Services	toll-free: 0-800-444-0724
Aruba	General Support	toll-free: 800-1578
Australia (Sydney) International Access Code: 0011 Country Code: 61 City Code: 2	E-mail (Australia): au_tech_support@dell.com	
	E-mail (New Zealand): nz_tech_support@dell.com	
	Home and Small Business	1-300-655-533
	Government and Business	toll-free: 1-800-633-559
	Preferred Accounts Division (PAD)	toll-free: 1-800-060-889
	Customer Care	toll-free: 1-800-819-339
	Technical Support (portables and desktops)	toll-free: 1-300-655-533
	Technical Support (servers and workstations)	toll-free: 1-800-733-314
	Corporate Sales	toll-free: 1-800-808-385
	Transaction Sales	toll-free: 1-800-808-312
Austria (Vienna) International Access Code: 900 Country Code: 43 City Code: 1	Website: support.euro.dell.com	
	E-mail: tech_support_central_europe@dell.com	
	Home/Small Business Sales	0820 240 530 00
	Home/Small Business Fax	0820 240 530 49
	Home/Small Business Customer Care	0820 240 530 14
	Preferred Accounts/Corporate Customer Care	0820 240 530 16
	Home/Small Business Technical Support	0820 240 530 14

	Preferred Accounts/Corporate Technical Support	0660 8779
	Switchboard	0820 240 530 00
Bahamas	General Support	toll-free: 1-866-278-6818
Barbados	General Support	1-800-534-3066
Belgium (Brussels) International Access Code: 00 Country Code: 32 City Code: 2	Website: support.euro.dell.com	
	E-mail for French-speaking Customers: support.euro.dell.com/be/fr/emaildell/	
	Technical Support	02 481 92 88
	Technical Support Fax	02 481 92 95
	Customer Care	02 713 15 .65
	Corporate Sales	02 481 91 00
	Fax	02 481 92 99
	Switchboard	02 481 91 00
Bermuda	General Support	1-800-342-0671
Bolivia	General Support	toll-free: 800-10-0238
Brazil International Access Code: 00 Country Code: 55 City Code: 51	Website: www.dell.com/br	
	Customer Support, Technical Support	0800 90 3355
	Technical Support Fax	51 481 5470
	Customer Care Fax	51 481 5480
	Sales	0800 90 3390
British Virgin Islands	General Support	toll-free: 1-866-278-6820
Brunei Country Code: 673	Customer Technical Support (Penang, Malaysia)	604 633 4966
	Customer Service (Penang, Malaysia)	604 633 4949
	Transaction Sales (Penang, Malaysia)	604 633 4955
Canada (North York, Ontario) International Access Code: 011	Online Order Status: www.dell.ca/ostatus	
	AutoTech (automated technical support)	toll-free: 1-800-247-9362
	Customer Care (Home Sales/Small Business)	toll-free: 1-800-847-4096
	Customer Care (med./large business, government)	toll-free: 1-800-326-9463
	Technical Support (Home Sales/Small Business)	toll-free: 1-800-847-4096
	Technical Support (med./large bus., government)	toll-free: 1-800-387-5757
	Sales (Home Sales/Small Business)	toll-free: 1-800-387-5752
	Sales (med./large bus., government)	toll-free: 1-800-387-5755
	Spare Parts Sales & Extended Service Sales	1 866 440 3355
Cayman Islands	General Support	1-800-805-7541
Chile (Santiago) Country Code: 56 City Code: 2	Sales, Customer Support, and Technical Support	toll-free: 1230-020-4823
	Technical Support website: support.dell.com.cn	
	Technical Support E-mail: cn_support@dell.com	
	Customer Care E-mail: customer_cn@dell.com	
	Technical Support Fax	818 1350
	Technical Support (Dell™ Dimension™ and Inspiron™)	toll-free: 800 858 2969
	Technical Support (OptiPlex™, Latitude™, and Dell Precision™)	toll-free: 800 858 0950
	Technical Support (servers and storage)	toll-free: 800 858 0960

China (Xiamen) Country Code: 86 City Code: 592	Technical Support (projectors, PDAs, printers, switches, routers, and so on)	toll-free: 800 858 2920
	Customer Care	toll-free: 800 858 2060
	Customer Care Fax	592 818 1308
	Home and Small Business	toll-free: 800 858 2222
	Preferred Accounts Division	toll-free: 800 858 2557
	Large Corporate Accounts GCP	toll-free: 800 858 2055
	Large Corporate Accounts Key Accounts	toll-free: 800 858 2628
	Large Corporate Accounts North	toll-free: 800 858 2999
	Large Corporate Accounts North Government and Education	toll-free: 800 858 2955
	Large Corporate Accounts East	toll-free: 800 858 2020
	Large Corporate Accounts East Government and Education	toll-free: 800 858 2669
	Large Corporate Accounts Queue Team	toll-free: 800 858 2572
	Large Corporate Accounts South	toll-free: 800 858 2355
	Large Corporate Accounts West	toll-free: 800 858 2811
	Large Corporate Accounts Spare Parts	toll-free: 800 858 2621
Colombia	General Support	980-9-15-3978
Costa Rica	General Support	0800-012-0435
Czech Republic (Prague) International Access Code: 00 Country Code: 420	Website: support.euro.dell.com	
	E-mail: czech_dell@dell.com	
	Technical Support	22537 2727
	Customer Care	22537 2707
	Fax	22537 2714
	Tech Fax	22537 2728
	Switchboard	22537 2711
Denmark (Copenhagen) International Access Code: 00 Country Code: 45	Website: support.euro.dell.com	
	E-mail: support.euro.dell.com/dk/da/emaildell/	
	Technical Support	7023 0182
	Customer Care (Relational)	7023 0184
	Home/Small Business Customer Care	3287 5505
	Switchboard (Relational)	3287 1200
	Switchboard Fax (Relational)	3287 1201
	Switchboard (Home/Small Business)	3287 5000
	Switchboard Fax (Home/Small Business)	3287 5001
Dominica	General Support	toll-free: 1-866-278-6821
Dominican Republic	General Support	1-800-148-0530
Ecuador	General Support	toll-free: 999-119
El Salvador	General Support	01-899-753-0777
Finland (Helsinki) International Access Code: 990 Country Code: 358 City Code: 9	Website: support.euro.dell.com	
	E-mail: support.euro.dell.com/fi/fi/emaildell/	
	Technical Support	09 253 313 60
	Customer Care	09 253 313 38
	Fax	09 253 313 99

	Switchboard	09 253 313 00
France (Paris) (Montpellier) International Access Code: 00 Country Code: 33 City Codes: (1) (4)	Website: support.euro.dell.com	
	E-mail: support.euro.dell.com/fr/fr/emaildell/	
	Home and Small Business	
	Technical Support	0825 387 270
	Customer Care	0825 823 833
	Switchboard	0825 004 700
	Switchboard (calls from outside of France)	04 99 75 40 00
	Sales	0825 004 700
	Fax	0825 004 701
	Fax (calls from outside of France)	04 99 75 40 01
	Corporate	
	Technical Support	0825 004 719
	Customer Care	0825 338 339
	Switchboard	01 55 94 71 00
	Sales	01 55 94 71 00
Fax	01 55 94 71 01	
Germany (Langen) International Access Code: 00 Country Code: 49 City Code: 6103	Website: support.euro.dell.com	
	E-mail: tech_support_central_europe@dell.com	
	Technical Support	06103 766-7200
	Home/Small Business Customer Care	0180-5-224400
	Global Segment Customer Care	06103 766-9570
	Preferred Accounts Customer Care	06103 766-9420
	Large Accounts Customer Care	06103 766-9560
	Public Accounts Customer Care	06103 766-9555
Switchboard	06103 766-7000	
Greece International Access Code: 00 Country Code: 30	Website: support.euro.dell.com	
	E-mail: support.euro.dell.com/gr/en/emaildell/	
	Technical Support	00800-44 14 95 18
	Gold Service Technical Support	00800-44 14 00 83
	Switchboard	2108129810
	Gold Service Switchboard	2108129811
	Sales	2108129800
Fax	2108129812	
Grenada	General Support	toll-free: 1-866-540-3355
Guatemala	General Support	1-800-999-0136
Guyana	General Support	toll-free: 1-877-270-4609
Hong Kong International Access Code: 001 Country Code: 852	Website: support.ap.dell.com	
	Technical Support E-mail: apsupport@dell.com	
	Technical Support (Dimension and Inspiron)	2969 3188
	Technical Support (OptiPlex, Latitude, and Dell Precision)	2969 3191
	Technical Support (PowerApp™, PowerEdge™, PowerConnect™, and PowerVault™)	2969 3196
	Customer Care	3416 0910
	Large Corporate Accounts	3416 0907

	Global Customer Programs	3416 0908
	Medium Business Division	3416 0912
	Home and Small Business Division	2969 3105
India	Technical Support	1600 33 8045
	Sales (Large Corporate Accounts)	1600 33 8044
	Sales (Home and Small Business)	1600 33 8046
Ireland (Cherrywood) International Access Code: 16 Country Code: 353 City Code: 1	Website: support.euro.dell.com	
	E-mail: dell_direct_support@dell.com	
	Technical Support	1850 543 543
	U.K. Technical Support (dial within U.K. only)	0870 908 0800
	Home User Customer Care	01 204 4014
	Small Business Customer Care	01 204 4014
	U.K. Customer Care (dial within U.K. only)	0870 906 0010
	Corporate Customer Care	1850 200 982
	Corporate Customer Care (dial within U.K. only)	0870 907 4499
	Ireland Sales	01 204 4444
	U.K. Sales (dial within U.K. only)	0870 907 4000
	Fax/Sales Fax	01 204 0103
	Switchboard	01 204 4444
Italy (Milan) International Access Code: 00 Country Code: 39 City Code: 02	Website: support.euro.dell.com	
	E-mail: support.euro.dell.com/it/it/emaildell/	
	Home and Small Business	
	Technical Support	02 577 826 90
	Customer Care	02 696 821 14
	Fax	02 696 821 13
	Switchboard	02 696 821 12
	Corporate	
	Technical Support	02 577 826 90
	Customer Care	02 577 825 55
	Fax	02 575 035 30
	Switchboard	02 577 821
	Jamaica	General Support (dial from within Jamaica only)
Japan (Kawasaki) International Access Code: 001 Country Code: 81 City Code: 44	Website: support.jp.dell.com	
	Technical Support (servers)	toll-free: 0120-198-498
	Technical Support outside of Japan (servers)	81-44-556-4162
	Technical Support (Dimension and Inspiron)	toll-free: 0120-198-226
	Technical Support outside of Japan (Dimension and Inspiron)	81-44-520-1435
	Technical Support (Dell Precision, OptiPlex, and Latitude)	toll-free: 0120-198-433
	Technical Support outside of Japan (Dell Precision, OptiPlex, and Latitude)	81-44-556-3894
	Technical Support (PDAs, projectors, printers, routers)	toll-free: 0120-981-690
	Technical Support outside of Japan (PDAs, projectors, printers, routers)	81-44-556-3468
	Faxbox Service	044-556-3490
	24-Hour Automated Order Service	044-556-3801

	Customer Care	044-556-4240
	Business Sales Division (up to 400 employees)	044-556-1465
	Preferred Accounts Division Sales (over 400 employees)	044-556-3433
	Large Corporate Accounts Sales (over 3500 employees)	044-556-3430
	Public Sales (government agencies, educational institutions, and medical institutions)	044-556-1469
	Global Segment Japan	044-556-3469
	Individual User	044-556-1760
	Switchboard	044-556-4300
Korea (Seoul) International Access Code: 001 Country Code: 82 City Code: 2	Technical Support	toll-free: 080-200-3800
	Sales	toll-free: 080-200-3600
	Customer Service (Penang, Malaysia)	604 633 4949
	Fax	2194-6202
	Switchboard	2194-6000
	Technical Support (Electronics and Accessories)	toll-free: 080-200-3801
Latin America	Customer Technical Support (Austin, Texas, U.S.A.)	512 728-4093
	Customer Service (Austin, Texas, U.S.A.)	512 728-3619
	Fax (Technical Support and Customer Service) (Austin, Texas, U.S.A.)	512 728-3883
	Sales (Austin, Texas, U.S.A.)	512 728-4397
	SalesFax (Austin, Texas, U.S.A.)	512 728-4600 or 512 728-3772
Luxembourg International Access Code: 00 Country Code: 352	Website: support.euro.dell.com	
	E-mail: tech_be@dell.com	
	Technical Support (Brussels, Belgium)	3420808075
	Home/Small Business Sales (Brussels, Belgium)	toll-free: 080016884
	Corporate Sales (Brussels, Belgium)	02 481 91 00
	Customer Care (Brussels, Belgium)	02 481 91 19
	Fax (Brussels, Belgium)	02 481 92 99
	Switchboard (Brussels, Belgium)	02 481 91 00
Macao Country Code: 853	Technical Support	toll-free: 0800 105
	Customer Service (Xiamen, China)	34 160 910
	Transaction Sales (Xiamen, China)	29 693 115
Malaysia (Penang) International Access Code: 00 Country Code: 60 City Code: 4	Website: support.ap.dell.com	toll-free: 1 800 88 0193
	Technical Support (Dell Precision, OptiPlex, and Latitude)	toll-free: 1 800 88 1306
	Technical Support (Dimension, Inspiron, and Electronics and Accessories)	
	Technical Support (PowerApp, PowerEdge, PowerConnect, and PowerVault)	toll-free: 1800 88 1386
	Customer Service (Penang, Malaysia)	04 633 4949
	Transaction Sales	toll-free: 1 800 888 202
	Corporate Sales	toll-free: 1 800 888 213
Mexico International Access Code: 00 Country Code: 52	Customer Technical Support	001-877-384-8979 or 001-877-269-3383
	Sales	50-81-8800 or 01-800-888-3355
	Customer Service	001-877-384-8979

		or 001-877-269-3383
	Main	50-81-8800 or 01-800-888-3355
Montserrat	General Support	toll-free: 1-866-278-6822
Netherlands Antilles	General Support	001-800-882-1519
Netherlands (Amsterdam) International Access Code: 00 Country Code: 31 City Code: 20	Website: support.euro.dell.com	
	Technical Support	020 674 45 00
	Technical Support Fax	020 674 47 66
	Home/Small Business Customer Care	020 674 42 00
	Relational Customer Care	020 674 4325
	Home/Small Business Sales	020 674 55 00
	Relational Sales	020 674 50 00
	Home/Small Business Sales Fax	020 674 47 75
	Relational Sales Fax	020 674 47 50
	Switchboard	020 674 50 00
	Switchboard Fax	020 674 47 50
New Zealand International Access Code: 00 Country Code: 64	E-mail (New Zealand): nz_tech_support@dell.com	
	E-mail (Australia): au_tech_support@dell.com	
	Technical Support (for desktop and portable computers)	toll-free: 0800 446 255
	Technical Support (for servers and workstations)	toll-free: 0800 443 563
	Home and Small Business	0800 446 255
	Government and Business	0800 444 617
	Sales	0800 441 567
	Fax	0800 441 566
Nicaragua	General Support	001-800-220-1006
Norway (Lysaker) International Access Code: 00 Country Code: 47	Website: support.euro.dell.com	
	E-mail: support.euro.dell.com/no/no/emaildell/	
	Technical Support	671 16882
	Relational Customer Care	671 17575
	Home/Small Business Customer Care	23162298
	Switchboard	671 16800
	Fax Switchboard	671 16865
Panama	General Support	001-800-507-0962
Peru	General Support	0800-50-669
Poland (Warsaw) International Access Code: 011 Country Code: 48 City Code: 22	Website: support.euro.dell.com	
	E-mail: pl_support_tech@dell.com	
	Customer Service Phone	57 95 700
	Customer Care	57 95 999
	Sales	57 95 999
	Customer Service Fax	57 95 806
	Reception Desk Fax	57 95 998
	Switchboard	57 95 999
Portugal	Website: support.euro.dell.com	

International Access Code: 00 Country Code: 351	E-mail: support.euro.dell.com/pt/en/emaildell/	
	Technical Support	707200149
	Customer Care	800 300 413
	Sales	800 300 410 or 800 300 411 or 800 300 412 or 21 422 07 10
	Fax	21 424 01 12
Puerto Rico	General Support	1-800-805-7545
St. Kitts and Nevis	General Support	toll-free: 1-877-441-4731
St. Lucia	General Support	1-800-882-1521
St. Vincent and the Grenadines	General Support	toll-free: 1-877-270-4609
Singapore (Singapore) International Access Code: 005 Country Code: 65	Website: support.ap.dell.com	
	Technical Support (Dimension, Inspiron, and Electronics and Accessories)	toll-free: 1800 394 7430
	Technical Support (OptiPlex, Latitude, and Dell Precision)	toll-free: 1800 394 7488
	Technical Support (PowerApp, PowerEdge, PowerConnect, and PowerVault)	toll-free: 1800 394 7478
	Customer Service (Penang, Malaysia)	604 633 4949
	Transaction Sales	toll-free: 1 800 394 7412
	Corporate Sales	toll-free: 1 800 394 7419
Slovakia (Prague) International Access Code: 00 Country Code: 421	Website: support.euro.dell.com	
	E-mail: czech_dell@dell.com	
	Technical Support	02 5441 5727
	Customer Care	420 22537 2707
	Fax	02 5441 8328
	Tech Fax	02 5441 8328
	Switchboard (Sales)	02 5441 7585
South Africa (Johannesburg) International Access Code: 09/091 Country Code: 27 City Code: 11	Website: support.euro.dell.com	
	E-mail: dell_za_support@dell.com	
	Gold Queue	011 709 7713
	Technical Support	011 709 7710
	Customer Care	011 709 7707
	Sales	011 709 7700
	Fax	011 706 0495
	Switchboard	011 709 7700
Southeast Asian and Pacific Countries	Customer Technical Support, Customer Service, and Sales (Penang, Malaysia)	604 633 4810
Spain (Madrid) International Access Code: 00 Country Code: 34 City Code: 91	Website: support.euro.dell.com	
	E-mail: support.euro.dell.com/es/es/emaildell/	
	Home and Small Business	
	Technical Support	902 100 130
	Customer Care	902 118 540
	Sales	902 118 541
	Switchboard	902 118 541
	Fax	902 118 539
	Corporate	
	Technical Support	902 100 130
Customer Care	902 115 236	

	Switchboard	91 722 92 00
	Fax	91 722 95 83
Sweden (Upplands Vasby) International Access Code: 00 Country Code: 46 City Code: 8	Website: support.euro.dell.com	
	E-mail: support.euro.dell.com/se/sv/emaildell/	
	Technical Support	08 590 05 199
	Relational Customer Care	08 590 05 642
	Home/Small Business Customer Care	08 587 70 527
	Employee Purchase Program (EPP) Support	20 140 14 44
	Technical Support Fax	08 590 05 594
	Sales	08 590 05 185
Switzerland (Geneva) International Access Code: 00 Country Code: 41 City Code: 22	Website: support.euro.dell.com	
	E-mail: Tech_support_central_Europe@dell.com	
	E-mail for French-speaking HSB and Corporate Customers: support.euro.dell.com/ch/fr/emaildell/	
	Technical Support (Home and Small Business)	0844 811 411
	Technical Support (Corporate)	0844 822 844
	Customer Care (Home and Small Business)	0848 802 202
	Customer Care (Corporate)	0848 821 721
	Fax	022 799 01 90
Switchboard	022 799 01 01	
Taiwan International Access Code: 002 Country Code: 886	Website: support.ap.dell.com	
	E-mail: ap_support@dell.com	
	Technical Support (OptiPlex, Latitude, Inspiron, Dimension, and Electronics and Accessories)	toll-free: 00801 86 1011
	Technical Support (PowerApp, PowerEdge, PowerConnect, and PowerVault)	toll-free: 00801 60 1256
	Transaction Sales	toll-free: 00801 65 1228
	Corporate Sales	toll-free: 00801 651 227
Thailand International Access Code: 001 Country Code: 66	Website: support.ap.dell.com	
	Technical Support (OptiPlex, Latitude, and Dell Precision)	toll-free: 1800 0060 07
	Technical Support (PowerApp, PowerEdge, PowerConnect, and PowerVault)	toll-free: 1800 0600 09
	Customer Service (Penang, Malaysia)	604 633 4949
	Corporate Sales	toll-free: 1800 006 009
Transaction Sales	toll-free: 1800 006 006	
Trinidad/Tobago	General Support	1-800-805-8035
Turks and Caicos Islands	General Support	toll-free: 1-866-540-3355
U.K. (Bracknell) International Access Code: 00 Country Code: 44 City Code: 1344	Website: support.euro.dell.com	
	Customer Care website: support.euro.dell.com/uk/en/ECare/Form/Home.asp	
	E-mail: dell_direct_support@dell.com	
	Technical Support (Corporate/Preferred Accounts/PAD [1000+ employees])	0870 908 0500
	Technical Support (direct and general)	0870 908 0800
	Global Accounts Customer Care	01344 373 186
	Home and Small Business Customer Care	0870 906 0010
	Corporate Customer Care	01344 373 185
Preferred Accounts (500–5000 employees) Customer Care	0870 906 0010	

	Central Government Customer Care	01344 373 193	
	Local Government & Education Customer Care	01344 373 199	
	Health Customer Care	01344 373 194	
	Home and Small Business Sales	0870 907 4000	
	Corporate/Public Sector Sales	01344 860 456	
	Home and Small Business Fax	0870 907 4006	
Uruguay	General Support	toll-free: 000-413-598-2521	
U.S.A. (Austin, Texas) International Access Code: 011 Country Code: 1	Automated Order-Status Service	toll-free: 1-800-433-9014	
	AutoTech (portable and desktop computers)	toll-free: 1-800-247-9362	
	Consumer (Home and Home Office)		
	Technical Support	toll-free: 1-800-624-9896	
	Customer Service	toll-free: 1-800-624-9897	
	DellNet™ Service and Support	toll-free: 1-877-Dellnet (1-877-335-5638)	
	Employee Purchase Program (EPP) Customers	toll-free: 1-800-695-8133	
	Financial Services website: www.dellfinancialservices.com		
	Financial Services (lease/loans)	toll-free: 1-877-577-3355	
	Financial Services (Dell Preferred Accounts [DPA])	toll-free: 1-800-283-2210	
	Business		
	Customer Service and Technical Support	toll-free: 1-800-822-8965	
	Employee Purchase Program (EPP) Customers	toll-free: 1-800-695-8133	
	Printers and Projectors Technical Support	toll-free: 1-877-459-7298	
	Public (government, education, and healthcare)		
	Customer Service and Technical Support	toll-free: 1-800-456-3355	
	Employee Purchase Program (EPP) Customers	toll-free: 1-800-234-1490	
	Dell Sales	toll-free: 1-800-289-3355 or toll-free: 1-800-879-3355	
	Dell Outlet Store (Dell refurbished computers)	toll-free: 1-888-798-7561	
	Software and Peripherals Sales	toll-free: 1-800-671-3355	
	Spare Parts Sales	toll-free: 1-800-357-3355	
	Extended Service and Warranty Sales	toll-free: 1-800-247-4618	
	Fax	toll-free: 1-800-727-8320	
	Dell Services for the Deaf, Hard-of-Hearing, or Speech-Impaired	toll-free: 1-877-DELLTTY (1-877-335-5889)	
	U.S. Virgin Islands	General Support	1-877-673-3355
	Venezuela	General Support	8001-3605

Regulatory Notices

TCO(TCO'99)



Congratulations!

You have just purchased a TCO'99 approved and labelled product! Your choice has provided you with a product developed for professional use. Your purchase has also contributed to reducing the burden on the environment and also to the further development of environmentally adapted electronics products.

Why do we have environmentally labelled computers?

In many countries, environmental labelling has become an established method for encouraging the adaptation of goods and services to the environment. With the growing manufacture and usage of electronic equipment throughout the world, there is a recognized concern for the materials and substances used by electronic products with regards to their eventual recycling and disposal. By proper selection of these materials and substances, the impact on the environment can be minimized.

There are also other characteristics of a computer, such as energy consumption levels, that are important from the viewpoints of both the work (internal) and natural (external) environments. Electronic equipment in offices is often left running continuously, resulting in unnecessary consumption of large amounts of energy and additional power generation. From the standpoint of carbon dioxide emissions alone, it is vital to save energy.

What does labelling involve?

The product meets the requirements for the TCO'99 scheme which provides for international and environmental labelling of personal computers and/or displays. The labelling scheme was developed as a joint effort by the TCO (The Swedish Confederation of Professional Employees), Svenska Naturskyddsforeningen (The Swedish Society for Nature Conservation) and Statens Energimyndighet (The Swedish National Energy Administration).

Approval requirements cover a wide range of issues: ecology, ergonomics, emission of electrical and magnetical fields, energy consumption and electrical safety.

Ecological criteria impose restrictions on the presence and use of heavy metals, brominated and chlorinated flame retardants, and other substances. The product must be prepared for recycling and the manufacturing site(s) shall be certified according to ISO14001 or EMAS registered.

Energy requirements include a demand that the system unit and/or display, after a certain period of inactivity, shall reduce its power consumption to a lower level in one or more stages. The length of time to reactivate the system unit shall be reasonable for the user.

Labelled products must meet strict environmental demands, for example, in respect of the reduction of electrical and magnetical fields as well as work load and visual ergonomics.

Below you will find a brief summary of the ecological requirements met by this product. The complete ecological criteria document can be found at TCO Development's website <http://www.tcodevelopment.com> or may be ordered from:

TCO Development

SE-114 94 STOCKHOLM, Sweden

Fax: +46 8 782 92 07

E-mail: development@tco.se

Information regarding TCO'99 approved and labelled products may also be obtained at <http://www.tcodevelopment.com>

Ecological requirements

Flame retardants

Flame retardants may be present in printed wiring board laminates, cables, and housings. Their purpose is to prevent, or at least to delay the spread of fire. Up to 30% by weight of the plastic in a computer casing can consist of flame retardant substances. Many flame retardants contain bromine or chlorine, and these flame retardants are chemically related to PCBs (polychlorinated biphenyls). Both the flame retardants containing bromine or chlorine and the PCBs are suspected of giving rise to health effects, including reproductive damage in fish-eating birds and mammals, due to the bio-accumulative* processes when not disposed of in accordance with strict standards for disposal.

TCO'99 requires that plastic components weighing more than 25 grams shall not contain flame retardants with organically bound bromine or chlorine. Flame retardants are allowed in the printed wiring board laminates due to the lack of commercially available alternatives.

Cadmium

Cadmium is present in rechargeable batteries and in the colour-generating layers of certain computer displays. TCO'99 requires that batteries, the colour-generating layers of display screens, and the electrical or electronics components shall not contain any cadmium.

Mercury**

Mercury is sometimes found in batteries, relays and switches. TCO'99 requires that batteries shall not contain any mercury. It also demands that mercury is not present in any of the electrical or electronics components associated with the labelled unit. There is however one exception. Mercury is, for the time being, permitted in the back light system of flat panel monitors as there today is no commercially available alternative. TCO aims on removing this exception when a mercury free alternative is available.

Lead**

Lead can be found in picture tubes, display screens, solders and capacitors. TCO'99 permits the use of lead due to the lack of commercially available alternatives, but in future requirements TCO Development aims at restricting the use of lead.

* Bio-accumulative is defined as substances which accumulate in living organisms.

**Lead, Cadmium and Mercury are heavy metals which are bio-accumulative.

TCO(TCO'03)



Congratulations!

The display you have just purchased carries the TCO'03 Displays label. This means that your display is designed, manufactured and tested according to some of the strictest quality and environmental requirements in the world. This makes for a high performance product, designed with the user in focus that also minimizes the impact on our natural environment.

Some of the features of the TCO'03 Display requirements:

Ergonomics

- Good visual ergonomics and image quality in order to improve the working environment for the user and to reduce sight and strain problems. Important parameters are luminance, contrast, resolution, reflectance, colour rendition and image stability.

Energy

- Energy-saving mode after a certain time - beneficial both for the user and the environment
- Electrical safety

Emissions

- Electromagnetic fields
- Noise emissions

Ecology

- The product must be prepared for recycling and the manufacturer must have a certified environmental management system such as EMAS or ISO 14000
- Restrictions on
 - chlorinated and brominated flame retardants and polymers
 - heavy metals such as cadmium, mercury and lead.

The requirements included in this label have been developed by TCO Development in cooperation with scientists, experts, users as well as manufacturers all over the world. Since the end of the 1980s TCO has been involved in influencing the development of IT equipment in a more user-friendly direction. Our labelling system started with displays in 1992 and is now requested by users and IT-manufacturers all over the world.

For more information, please visit
www.tcodevelopment.com

Energy Efficiency



The proper operation of the function requires a computer with VESA® DPM™ power management capabilities. When used with a computer equipped with VESA® DPM™, the monitor is **ENERGY STAR®**-compliant.
As an **ENERGY STAR®** Partner, Dell Inc. has determined that this product meets the **ENERGY STAR®** guidelines for energy efficiency.

Federal Communications Commission (FCC) Notice (U.S. Only)

⚠ CAUTION: This equipment has been tested and found to comply with the limits for a Class B digital device, pursuant to Part 15 of the FCC Rules. These limits are designed to provide reasonable protection against harmful interference in a residential installation. This equipment generates, uses, and can radiate radio frequency energy and, if not installed and used in accordance with the instructions, may cause harmful interference to radio communications. However, there is no guarantee that interference will not occur in a particular installation. If this equipment does cause harmful interference to radio or television reception, which can be determined by turning the equipment off and on, the user is encouraged to try to correct the interference by one or more of the following measures:

- Reorient or relocate receiving antenna.
- Increase the separation between the equipment and receiver.
- Connect the equipment into an outlet on a circuit different from that to which the receiver is connected.
- Consult the dealer or an experienced radio/TV technician for help.

This device complies with Part 15 of the FCC rules. Operation is subject to the following two conditions:

- This device may not cause harmful interference.
- This device must accept any interference received including interference that may cause undesired operation.

Instructions to Users: This equipment complies with the requirements of FCC (Federal Communication Commission) equipment provided that following conditions are met.

1. Power cable: Shielded power cable should be used.
2. Video inputs: The input signal amplitude must not exceed the specified level.

⚠ NOTICE: Changes or modifications not expressly approved by the party responsible for compliance could void the user's authority to operate the equipment.

FCC Declaration of Conformity

According to 47 CFR, Part 15 of the FCC Rules

* **For the following named product :**

COLOR MONITOR
(Category Name)

1704FPVt / DELL
(Model No / Brand Name) (Basic Model)

* **Manufactured at :**

LITEON TECHNOLOGY CORP.

We hereby declare that this device complies with Part 15 of the FCC Rules.
Operation is subject to the following two conditions :

1. This device may not cause harmful interference, and
2. This device must accept any interference received,
including interference that may cause undesired operation.

* **FCC Rules :**

Tested to comply with FCC part 15, class B

* **Test site at :**

SPORTON International Inc.

* **Responsible Party for Product Compliance :**

QA Lab of LITEON

392, Ruey, Kuang Road, Neihu, Taipei 114, Taiwan R.O.C.
Tel) 8798-2888 Fax) 8798-2829

*** Manufacturer Information :**

LITEON Technology Corp.
392, Ruey, Kuang Road, Neihu, Taipei 114, Taiwan R.O.C.

2004-08-05

Display Division
EMC Department
Manager



Douglas Yang / Manager
(name and signature of authorized person)

(place and date of issue)

EU Declaration of Conformity (LVD, EMC)

For the following product:

COLOR MONITOR
(category name)

1704FPVt
(model name)

Manufactured at :

1.LITEON Technology Corp.
392, Ruey, Kuang Road, Neihu, Taipei 114, Taiwan R.O.C.
(factory name, address)

We hereby declare, that all major safety requirements, concerning to CE-Mark Directive (93/68/EEC) and Low Voltage Directive (73/23/EEC), Electromagnetic Compatibility Directives (89/336/EEC, 92/31/EEC) are fulfilled, as laid out in the guidelines set down by the member states of the EEC Commission. This declaration is valid for all samples that are part of this declaration, which are manufactured according to the production charts appendix. The standards relevant for the evaluation of electrical safety & EMC requirements are as follows :

LVD : EN 60950:2000

EMC : EN 55022:1998/A1:2000 Class B, EN 61000-3-2:2000, EN 61000-3-3:1995/A1:2001 and EN 55024:1998/A1:2001-LITEON

1. Certificate of conformity / Test report issued by :

EEMC : NEMKO, SPORTON International Inc.

LVD : NEMKO, TUV

2. Technical documentation kept at :

Liteon Technology Corp.

which will be made available upon request.

(Manufacturer)

LITEON Technology Corp.
392, Ruey, Kuang Road, Neihu, Taipei 114, Taiwan R.O.C.

2004-05-20

(place and date of issue)

Display Division
Safety Department
Manager

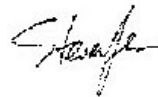

Steven Yen / Manager
(name and signature of authorized person)

(Representative in the EU)

LITEON Technology Corp.
392, Ruey, Kuang Road, Neihu, Taipei 114, Taiwan R.O.C.

2004-08-05

Display Division
EMC Department
Manager

Douglas Yang / Manager
(name and signature of authorized person)

(place and date of issue)

Canadian Regulatory Information (Canada Only)

This digital apparatus does not exceed the Class B limits for radio noise emissions from digital apparatus set out in the Radio Interference Regulations of the Canadian Department of Communications.

Note that Canadian Department of Communications (DOC) regulations provide, that changes or modifications not expressly approved by Dell Inc. could void your authority to operate this equipment.

This Class B digital apparatus meets all requirements of the Canadian Interference-Causing Equipment Regulations.

Cet appareil numérique de la classe B respecte toutes les exigences du Règlement sur le matériel brouilleur du Canada.

EN 55022 Compliance (Czech Republic Only)

This device belongs to category B devices as described in EN 55022, unless it is specifically stated that it is a category A device on the specification label. The following applies to devices in category A of EN 55022 (radius of protection up to 30 meters). The user of the device is obliged to take all steps necessary to remove sources of interference of telecommunication or other devices.

Pokud není na typovém štítku počítače uvedeno, že spadá do třídy A podle EN 55022, spadá automaticky do třídy B podle EN 55022. Pro zařízení zařazená do třídy A (chranné pásmo 30m) podle EN 55022 platí následující. Dojde-li k rušení telekomunikačních nebo jiných zařízení, je uživatel povinen provést taková opatření, aby rušení odstranil.

VCCI Class B Notice (Japan Only)

This equipment complies with the limits for a Class B digital device (devices used in or adjacent to a residential environment) and conforms to the standards for information technology equipment that are set by the Voluntary Control Council for Interference for preventing radio frequency interference in residential areas.



Class B ITE

この装置は、情報処理装置等電波障害自主規制協議会 (VCCI) の基準に基づくクラス B 情報技術装置です。この装置は家庭環境で使用することを目的としていますが、この装置がラジオやテレビジョン受信機に近接して使用されると、受信機障害を引き起こすことがあります。取扱説明書に従って正しい取扱いをお願いします。

MIC Notice (Republic of Korea Only)

Class B Device

기종별	사용자 안내문
B급 기기 (가정용 정보통신기기)	이 기기는 가정용으로 전자파적합등록을 한 기기로서 주거지역에서는 물론 모든 지역에서 사용할 수 있습니다.

	1. 기기의명칭(모델명): LCD MONITOR (1704FPV1)
	2. 인 중 번 호: E-B012-04-1946(B)
	3. 인증발안자의상호: LITE-ON TECHNOLOGY CORP.
	4. 제 조 년 월: LITE-ON TECHNOLOGY CORP. (대만)
	5. 제조자/제조국가: LITE-ON TECHNOLOGY CORP. (대만)

Please note that this device has been approved for non-business purposes and may be used in any environment, including residential areas.

Polish Center for Testing and Certification Notice

The equipment should draw power from a socket with an attached protection circuit (a three-prong socket). All equipment that works together (computer, monitor, printer, and so on) should have the same power supply source.

The phasing conductor of the room's electrical installation should have a reserve short-circuit protection device in the form of a fuse with a nominal value no larger than 16 amperes (A).

To completely switch off the equipment, the power supply cable must be removed from the power supply socket, which should be located near the equipment and easily accessible.

A protection mark "B" confirms that the equipment is in compliance with the protection usage requirements of standards PN-93/T-42107 and PN-89/E-06251.

Wymagania Polskiego Centrum Badań i Certyfikacji

Urządzenie powinno być zasilane z gniazda z przyłączonym obwodem ochronnym (gniazdo z kolkiem). Współpracujące ze sobą urządzenia (komputer, monitor, drukarka) powinny być zasilane z tego samego źródła.

Instalacja elektryczna pomieszczenia powinna zawierać w przewodzie fazowym rezerwową ochronę przed zwarciami, w postaci bezpiecznika o wartości znamionowej nie większej niż 16A (amperów).

W celu całkowitego wyłączenia urządzenia z sieci zasilania, należy wyjąć wtyczkę kabla zasilającego z gniazdka, które powinno znajdować się w pobliżu urządzenia i być łatwo dostępne.

Znak bezpieczeństwa "B" potwierdza zgodność urządzenia z wymaganiami bezpieczeństwa użytkowania zawartymi w PN-93/T-42107 i PN-89/E-06251.

Pozostałe instrukcje bezpieczeństwa

- Nie należy używać wtyczek adapterowych lub usuwać kolka obwodu ochronnego z wtyczki. Jeżeli konieczne jest użycie przedłużacza to należy użyć przedłużacza 3-żyłowego z prawidłowo połączonym przewodem ochronnym.
- System komputerowy należy zabezpieczyć przed nagłymi, chwilowymi wzrostami lub spadkami napięcia, używając eliminatora przepięć, urządzenia dopasowującego lub bezzakłócenowego źródła zasilania.
- Należy upewnić się, aby nic nie leżało na kablach systemu komputerowego, oraz aby kable nie były umieszczone w miejscu, gdzie można bytoby na nie nadeptywać lub potykać się o nie.
- Nie należy rozlewać napojów ani innych płynów na system komputerowy.
- Nie należy wpychać żadnych przedmiotów do otworów systemu komputerowego, gdyż może to spowodować pożar lub porażenie prądem, poprzez zwarcie elementów wewnętrznych.
- System komputerowy powinien znajdować się z dala od grzejników i źródeł ciepła. Ponadto, nie należy blokować otworów wentylacyjnych. Należy unikać kładzenia luźnych papierów pod komputer oraz umieszczania komputera w ciasnym miejscu bez możliwości cyrkulacji powietrza wokół niego.

NOM Information (Mexico Only)

The following information is provided on the device(s) described in this document in compliance with the requirements of the official Mexican standards (NOM):

Exporter:	Dell Inc. One Dell Way Round Rock, TX 78682
Importer:	Dell Computer de México, S.A. de C.V. Rio Lerma No. 302 - 4° Piso Col. Cuauhtemoc 16500 México, D.F.
Ship to:	Dell Computer de México, S.A. de C.V. al Cuidado de Kuehne & Nagel de México S. de R.I., Avenida Soles No. 55 Col. Peñon de los Baños, 15520 México, D.F.
Supply voltage:	100-240 Vac

BSMI Notice (Taiwan Only)

警告使用者：這是之類之資訊產品，在居住的環境中使用時，可能會造成無線電干擾，在這種情況下，使用者會被要求採取某些適當的對策。

Ergonomics Notice (Germany Only)

Under the requirements of German ergonomics standard EK 1/59-98, EK 1/60-98, graphics or characters:

1. Blue graphics or characters in dark background are not recommended. (This combination may increase eye fatigue due to poor visibility caused by low contrast.)
2. Graphics controller and monitor are recommended to be used in the following conditions:
 - Vertical frequency : 60 Hz or higher.
 - Display mode : Dark characters in bright background.

Ergonomie Hinweis (nur Deutschland)

Um den Anforderungen der deutschen Ergonomie-Norm EK 1/59-98, EK 1/60-98 zu entsprechen.

1. Wird empfohlen, die Grünfarbe Blau nicht auf dunklem Hintergrund zu verwenden (schlechte Erkennbarkeit. Augenbelastung bei zu geringem Zeichenkontrast).
2. Wird folgende Einstellung des Grafik-Controllers und Monitors empfohlen.
 - Vertikalfrequenz : 60 Hz oder höher.
 - Ohne Zellensprung.

Regulatory Listing

Safety Certifications:

- UL 60950
- NOM
- CE Mark-EN60950
- IEC 60950
- CCC
- CSA
- TUVGS
- NEMKO
- GOST
- PSB
- TUV-S
- SASO

EMC Certifications:

- FCC Part 15 Class B
- CE Mark-EN55022:1998, EN55024:1998, EN61000-3-2:1995, EN61000-3-3:1995
- VCCI Class B ITE
- MIC
- BSMI
- ICES-003
- C-Tick

Ergonomics:

- ENERGY STAR®
 - TUV GS
 - TCO '99
 - TCO '03
-

Recycling

Dell recommends that customers dispose of their used computer hardware, including monitors, in an environmentally sound manner. Potential methods include the reuse of parts or whole products and recycling of product, components, and/or materials.

For more information, please visit www.dell.com/recycling_programs and www.dell.com/environment.

Your Monitor Set-up Guide

To view PDF files (files with an extension of **.pdf**), click the document title. To save PDF files (files with an extension of **.pdf**) to your hard drive, right-click the document title, click **Save Target As** in Microsoft® Internet Explorer or **Save Link As** in Netscape Navigator, and then specify a location on your hard drive to which you want to save the files.

[Setup Guide \(.pdf \) \(9.05 MB\)](#)



NOTE: PDF files require Adobe™ Acrobat Reader, which can be downloaded from the Adobe website at www.adobe.com.
To view a PDF file, launch Acrobat Reader. Then click **File® Open** and select the PDF file.

[Back to Contents Page](#)

Setting Up Your Monitor

Paramétrer votre moniteur | Instalación del monitor | Configurar o monitor |
Inbetriebnahme des Monitors | Configurazione del monitor | Instalacja monitora
設定您的監視器 | 安装显示器 | モニターのセットアップ | 모니터 설치 | การตั้งหน้าจอ

Dell™ 1704FPV UltraSharp Flat Panel Monitor

www.dell.com | support.dell.com



Attach the monitor to the stand.

Fixez le moniteur sur le socle.
Acople el monitor a la base.
Coloque o monitor no suporte.
Den Monitor auf den Fuß befestigen.
Fissare il monitor alla base
Podłącz monitor do podstawy.
將監視器裝在腳座上
將显示器与底座相连。
モニターをスタンドに取り付けます。
모니터를 스탠드에 부착합니다.
ประกอบ มอนิเตอร์ กับขาตั้ง



Rotate the monitor and connect in one of the following ways:

Faites tourner le moniteur et réalisez la connexion en suivant l'une des méthodes ci-dessous:
Gire el monitor y conéctelo siguiendo uno de los métodos siguientes:
Rode o monitor e ligue-o seguindo um dos procedimentos seguintes:
Drehen Sie den Monitor und nehmen Sie die Verbindung auf eine der folgenden Weisen vor:
Ruotare il monitor e collegarlo come indicato di seguito:
Obróć monitor i połącz jednym z następujących sposobów:
旋轉監視器並以下列之一的方式連接:
旋轉显示器並以下列方式進行連接:
モニターを回転し、次の方法のどれかで接続します:
모니터를 회전시키고 다음 방법 중 하나로 연결합니다:
หมุนมอนิเตอร์ และต่อสายด้วยหนึ่งในวิธีต่อไปนี้:

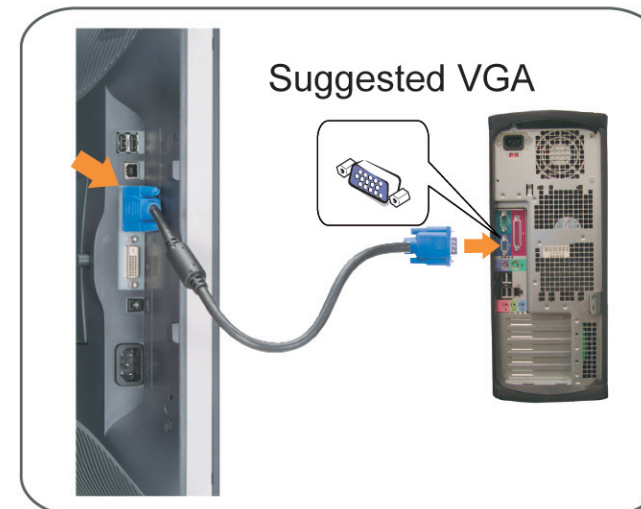

Connect the VGA cable or optional DVI cable to the computer.

Connectez le câble VGA ou le câble DVI optionnel à votre ordinateur.
Conecte el cable VGA o el cable DVI al equipo.
Ligue o cabo VGA ou o cabo DVI opcional ao computador.
Verbinden Sie das VGA-Kabel oder optionale DVI-Kabel mit dem Computer.
Collegare il cavo VGA o il cavo DVI opzionale al computer.
Podłącz do komputera kabel VGA lub opcjonalny kabel DVI.
將VGA電纜或選購的DVI電纜與電腦連接。
將VGA電纜或可選的DVI電纜與計算機相連。
VGAケーブルまたはオプションのDVIケーブルをコンピュータに接続します。
VGA 케이블 또는 선택품목인 DVI 케이블을 컴퓨터에 연결합니다.
ต่อสาย VGA หรือสาย DVI ซึ่งเป็นอุปกรณ์เสริม กับคอมพิวเตอร์.

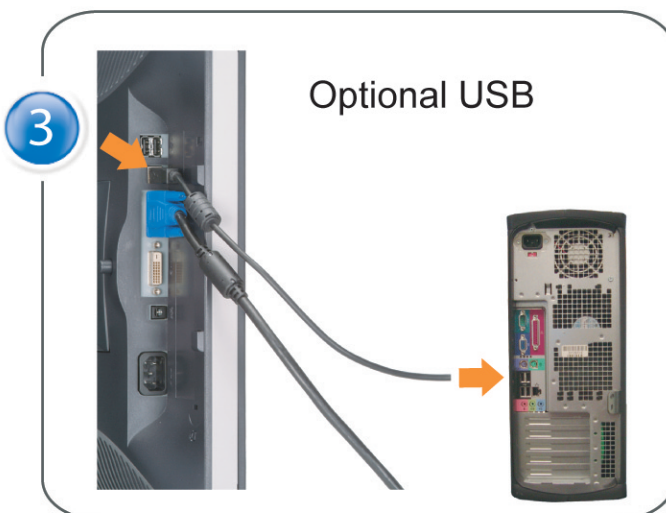
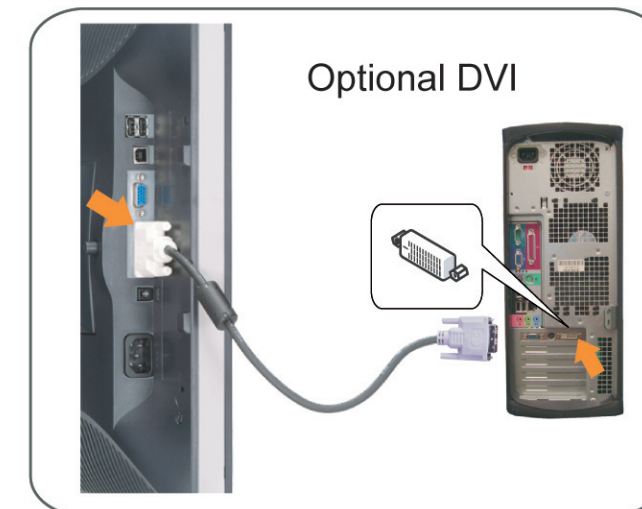

Connect the USB cable to the computer.

Connectez le câble USB sur l'ordinateur.
Conecte el cable USB a su computador.
Ligue o cabo USB ao computador.
Verbinden Sie das USB-Kabel mit dem Computer.
Collegare il cavo USB al computer.
Podłącz kabel USB do komputera
將USB纜線連接到電腦上。
將USB線連接到計算機。
USBケーブルをコンピュータに接続します。
USB 케이블을 컴퓨터에 연결합니다.
ต่อสาย USB เข้าคอมพิวเตอร์

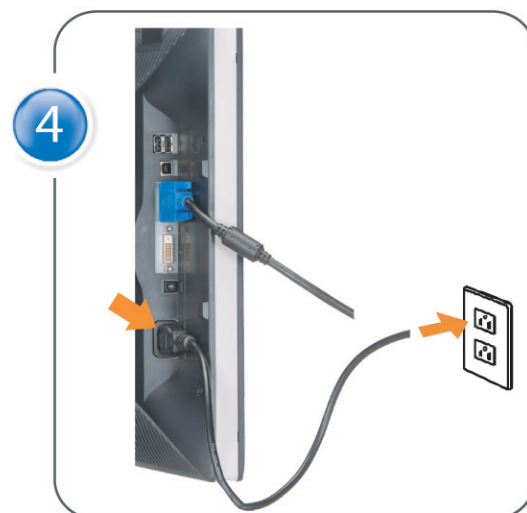

Connect the power cable to an electrical outlet.

Connectez le cordon d'alimentation sur une prise électrique.
Conecte el cable de alimentación a una toma de corriente.
Ligue o cabo de alimentação a uma tomada elétrica.
Stecken Sie den Netzstecker in eine Steckdose.
Collegare il cavo d'alimentazione ad una presa di corrente.
Podłącz kabel zasilający do gniazda elektrycznego.
將電源線連接到電源插座上。
將電源線連接到電源插座。
電源ケーブルをコンセントに接続します。
전원 케이블을 콘센트에 연결합니다.
เสียบสายไฟกับปลั๊ก



Turn on the monitor.

Allumez le moniteur.
Encienda el monitor.
Ligue o monitor.
Schalten Sie den Monitor ein.
Accendere il monitor.
Włącz monitor.
開啟監視器電源。
打開監視器電源。
モニターの電源をオンにします。
모니터를 켭니다.
เปิดมอนิเตอร์

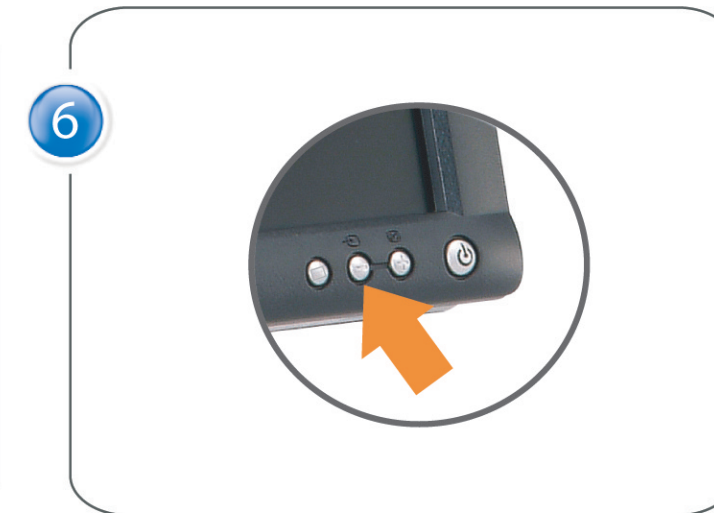

If nothing appears on the screen, press the Input Select button.

Si aucune image n'apparaît sur l'écran, appuyez sur le bouton Sélection d'Entrée.
Si no aparece nada en pantalla, pulse el botón Selección de entrada.
Se não aparecer nada no ecrã, prima o botão Seleção de entrada.
Wenn nichts auf dem Bildschirm erscheint, drücken Sie bitte die Eingangsauwahl-Taste.
Se sullo schermo non appare nulla, premere il tasto Seleziona ingresso.
Jeśli nic nie wyświetli się na ekranie, naciśnij przycisk Wybór wejścia.
若螢幕沒顯示畫面，請按“輸入選擇”按鈕。
如果屏幕上无显示，请按“输入选择”按钮。
画面に何も表示されない場合、「入力選択」ボタンを押してください。
화면에 아무것도 나타나지 않으면 [입력 선택] 버튼을 누릅니다.
หากไม่มีภาพปรากฏบนจอ ให้กดปุ่มเลือกสัญญาณเข้า (Input Select)



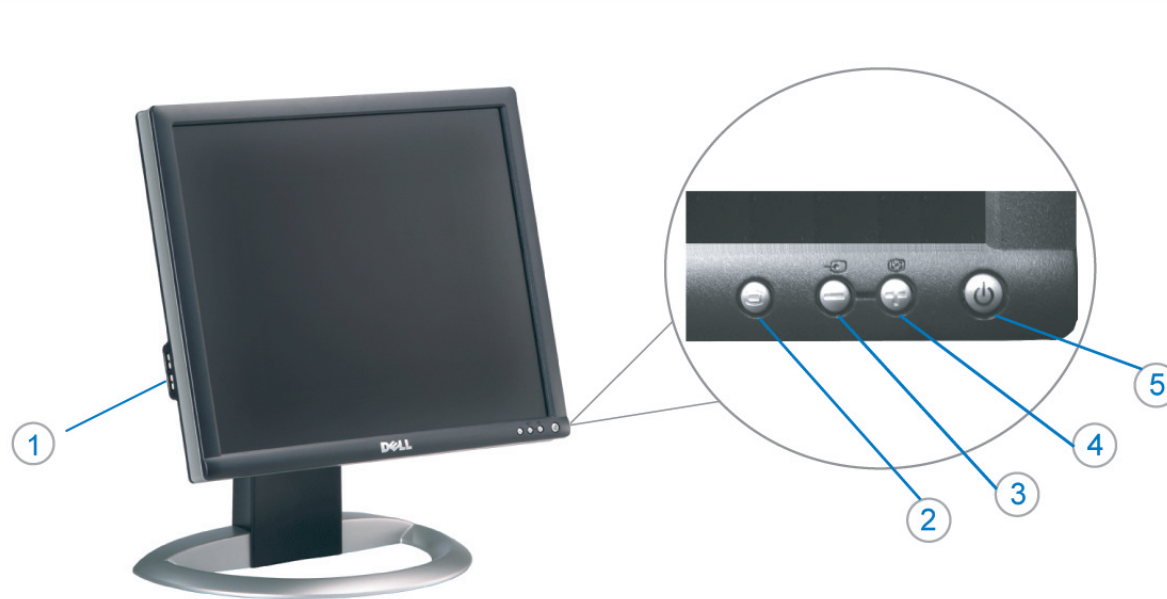

1. USB Downstream Connectors
2. OSD Menu/Select
3. Video Input Select/Down
4. Auto-Adjust/Up
5. Power Button
6. Cable Holder
7. Stand Lock/Release Button
8. Kensington Lock
9. Attachment Clips for Dell Soundbar
10. Power Out for Dell Soundbar
11. LCD Panel Lock/Release Button

1. Connecteurs USB aval
2. Menu OSD/Sélectionner
3. Sélectionner l'Entrée vidéo/Bas
4. Réglage auto/Haut
5. Bouton d'alimentation
6. Support de câble
7. Bouton verrouillage/déverrouillage du stand
8. Verrou Kensington
9. Clips accessoires pour Dell Soundbar
10. Sortie alimentation pour Dell Soundbar
11. Bouton verrouillage/déverrouillage du panneau LCD

1. Conectores inversos USB
2. Menú OSD/Seleccionar
3. Seleccionar entrada de vídeo/Bajar
4. Ajuste automático/Subir
5. Botón de encendido
6. Brida
7. Botón para fijar y liberar la base
8. Bloqueo Kensington
9. Broches de sujeción para Dell Soundbar
10. Desconexión para Dell Soundbar
11. Botón para bloquear o liberar el panel LCD

1. Conectores USB Downstream
2. Menu OSD/Seleccionar
3. Seleccionar entrada de vídeo/Para baixo
4. Ajuste automático/Para cima
5. Botão de alimentação
6. Suporte do cabo
7. Botão de bloqueio/desbloqueio
8. Bloqueio Kensington lock
9. Clips de fixação para o sistema de som Dell
10. Desligar sistema de som Dell
11. Botão de bloqueio/desbloqueio do painel LCD

1. USB Downstream-Anschlüsse
2. OSD Menü/Auswahl
3. Videoeingang-Auswahl/Unten
4. Auto-Einstellen/Oben
5. Ein-/Ausschalter
6. Kabelhalter
7. Ständer Ver-/Entriegelungstaste
8. Kensingtonschloss
9. Befestigung für Dell Soundbar
10. Ausschalter für Dell Soundbar
11. LCD-Bildschirm Ver-/Entriegelungstaste

1. Connettori USB scaricamento dei dati
2. Menu OSD/Selezione
3. Selezione ingresso video/Giù
4. Regolazione automatica/Su
5. Tasto alimentazione
6. Alloggio cavo
7. Tasto blocco/rilascio base
8. Lucchetto Kensington
9. Fermagli d'aggancio per Soundbar Dell
10. Uscita alimentazione per Soundbar Dell
11. Tasto blocco/rilascio pannello LCD

1. Złącza pobierania USB
2. Menu OSD/Wybór
3. Wybór wejścia video/W górę
4. Automatyczna regulacja/W górę
5. Przycisk zasilania
6. Uchwyt kabla
7. Przycisk blokady/zwolnienia obudowy
8. Blokada Kensington
9. Zaciski podłączenia Dell Soundbar (Panela dźwiękowego Dell)
10. Wyjście zasilania dla Dell Soundbar (Panela dźwiękowego Dell)
11. Przycisk blokady/zwolnienia panela LCD

1. USB 下行接口
2. OSD 功能表/選擇
3. 影像輸入選擇/下
4. 自動調整/上
5. 電源按鈕
6. 束線器
7. 腳座鎖定/鬆開按鈕
8. Kensington 鎖
9. Dell Soundbar 的連接夾 (Panela dźwiękowego Dell)
10. Dell Soundbar 電源輸出 (Panela dźwiękowego Dell)
11. LCD 面板鎖定/鬆開按鈕

1. USB 下游插頭
2. OSD 菜單/選擇
3. 視頻輸入選擇/向下
4. 自動調整/向上
5. 電源按鈕
6. 線纜固定夾
7. 底座鎖定/釋放按鈕
8. Kensington 鎖
9. Dell Soundbar 卡釘
10. Dell Soundbar 電源輸出
11. LCD 面板鎖定/釋放按鈕

1. USB downstream コネクタ
2. OSD メニュー/選択
3. ビデオ入力選択/下
4. 自動調整/上
5. 電源ボタン
6. ケーブルホルダー
7. スタンドロック/リリースボタン
8. ケンジントンロック
9. Dell Soundbar 用の取り付けクリップ
10. Dell Soundbar 用の電源ケーブル
11. LCD パネルロック/リリースボタン

1. USB downstream 커넥터
2. OSD 메뉴/선택
3. 비디오 입력 선택/아래로
4. 자동-조정/위로
5. 전원 버튼
6. 케이블 홀더
7. 스탠드 잠금/잠금 해제 버튼
8. Kensington 잠금 장치
9. Dell Soundbar 부착 클립
10. Dell Soundbar 전원 출력
11. LCD 패널 잠금/잠금 해제 버튼

1. ข้อต่อรับสัญญาณผ่านพอร์ต USB
2. เมนู OSD/เลือก
3. เลือกสัญญาณภาพเข้า/ลง
4. ปรับอัตโนมัติ/ขึ้น
5. ปุ่มเปิด/ปิด
6. ที่ยึดสาย
7. ปุ่มล็อค/ปลดล็อคขาตั้ง
8. ล็อคเคนชิงตัน
9. ที่ติดแถบเสียง Dell
10. ไฟฟ้าเข้าแถบเสียง Dell
11. ปุ่มล็อค/ปลดล็อคหน้าจอ LCD

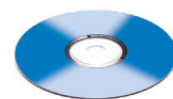

NOTE: Detailed user information is included on the CD.
 Remarque: Vous trouverez des informations détaillées sur le CD-Rom.
 NOTA: en el CD se incluyen más detalles para el usuario.
 NOTA: Informações detalhadas para o utilizador estão incluídas no CD.
 HINWEIS: Ausführliche Informationen sind auf der CD enthalten.
 NOTA: il CD contiene informazioni più dettagliate per l'utente.
 UWAGA: Szczegółowe informacje znajdują się na płycie CD.
 注意: 光碟中包含詳細的使用者資訊。
 注: 詳細的用戶信息包括在CD中。
 注: 詳細なユーザー情報は、CDに収録されています。
 注: 세부 사용자 설명서는 CD에 포함되어 있습니다.
 หมายเหตุ: ข้อมูลสำหรับผู้ใช้จะอยู่ในซีดี

Information in this document is subject to change without notice.
 © 2004 Dell Inc. All rights reserved.

Reproduction in any manner whatsoever without the written permission of Dell Inc. is strictly forbidden.

Dell and the DELL logo are trademarks of Dell Inc. Dell disclaims proprietary interest in the marks and names of others.
 August 2004

本指南的內容如有變更，恕不另行通知。
 © 2004 Dell Inc. 版權所有。

未經 Dell Inc. 的書面許可，嚴禁任何形式的非法複製。

Dell 及 DELL 標誌為 Dell Inc. 的商標。Dell 對其他 Dell 公司的商標和名稱的所有權均不為 Dell 所有。
 2004年8月

Les informations contenues dans ce document peuvent être soumises à des modifications sans préavis.
 © 2004 Dell Inc. Tous droits réservés.

Toute reproduction, par quelque manière que ce soit, est strictement interdite sans l'autorisation écrite de Dell Inc.

Dell et le logo DELL sont la propriété de Dell Inc. Tous les autres noms commerciaux ou noms de marques sont la propriété de leurs détenteurs respectifs.
 Août 2004

本指南的內容如有變更，恕不另行通知。
 © 2004 Dell Inc. 版權所有。

未經 Dell Inc. 的書面許可，嚴禁任何形式的非法複製。

Dell 和 DELL 標誌是 Dell Inc. 的商標。Dell 對其他 Dell 公司的商標和名稱的所有權均不為 Dell 所有。
 2004年8月

La información contenida en este documento está sujeta a cambios sin previo aviso.
 © 2004 Dell Inc. Reservados todos los derechos.

Se prohíbe estrictamente la reproducción de este documento en cualquier forma sin permiso por escrito de Dell Inc.

Dell y el logotipo DELL son marcas registradas de Dell Inc. Dell renuncia al derecho de posesión sobre las marcas y nombres de terceros.
 Agosto de 2004

本書に記載されている事項は事前通告無しに変更されることがあります。
 © 2004 年すべての著作権は Dell Inc. にあります。

Dell Inc. からの書面による許可なく本書の複製、転載を禁じます。

Dell と DELL のロゴマークは、Dell Inc. の登録商標です。上記記載以外の商標や会社名が使用されている場合がありますが、これらの商標や会社名は、一切 Dell Inc. に所属するものではありません。
 2004年8月

As informações contidas neste documento estão sujeitas a alterações sem aviso prévio.
 © 2004 Dell Inc. Corporation. Todos os direitos reservados.

A reprodução de qualquer forma sem permissão por escrito da Dell Inc. é estritamente proibida.

Dell e o logotipo DELL são marcas comerciais da Dell Inc. A Dell exclui quaisquer interesses de propriedade nas marcas e nomes de outros.
 Agosto 2004

이 안내서에 있는 내용은 사전 통보 없이 변경될 수 있습니다.
 © 2004 Dell Inc. 모든 권리 소유.

Dell Inc. 의 서면 승인없이 재적되는 복제 행위는 엄격히 금지됩니다.

Dell 과 Dell 로고는 Dell Inc. 의 등록상표입니다. Dell 은 회사 외의 상표 및 상품명에 대해서는 어떤 소유권도 인정하지 않습니다.
 2004년8월

Die Informationen in diesem Dokument unterliegen usangekündigten Änderungen.
 © 2004 Dell Inc. Alle Rechte vorbehalten.

Die Vervielfältigung dieses Dokuments in jeglicher Form ist ohne schriftliche Genehmigung der Dell Inc. streng untersagt.

Dell und das DELL-Logo sind Warenzeichen der Dell Inc. Dell erhebt keinerlei Eigentumsansprüche auf Warenzeichen und Namen Dritter.
 August 2004

เนื่องจากข้อมูลการเปลี่ยนแปลง อาจเกิดขึ้นได้ โดยไม่แจ้งเป็นก่อนแจ้งที่ทราบล่วงหน้า
 © 2004 Dell Inc. สงวนลิขสิทธิ์

ห้ามคัดลอก โดยไม่ได้รับอนุญาตจากบริษัท เดลล์ หรือผู้ขาย

Dell และโลโก้ Dell เป็นเครื่องหมายการค้าของบริษัท เดลล์ หรือผู้ขาย และเครื่องหมายการค้าของบริษัทอื่นที่คล้ายคลึงกันและเครื่องหมายการค้าที่เหมือนกัน
 สิงหาคม 2004

Le informazioni contenute in questo documento sono soggette a variazioni senza preavviso.
 © 2004 Dell Inc. Tutti i diritti riservati.

È severamente proibita la riproduzione di qualsiasi elemento senza il permesso scritto di Dell Inc.

Dell e il logo DELL sono marchi registrati di Dell Inc. Dell non riconosce interesse di proprietà esclusiva nei marchi e nelle denominazioni di altri.
 agosto 2004

本指南的內容如有變更，恕不另行通知。
 © 2004 Dell Inc. 版權所有。

未經 Dell Inc. 的書面許可，嚴禁任何形式的非法複製。

Dell 及 DELL 標誌為 Dell Inc. 的商標。Dell 對其他 Dell 公司的商標和名稱的所有權均不為 Dell 所有。
 2004年8月

Informacje zawarte w niniejszym dokumencie mogą ulec zmianie bez uprzedzenia.
 © 2004 Dell Inc. Wszystkie prawa zastrzeżone.

Powielanie niniejszego dokumentu przy użyciu jakiegokolwiek techniki bez pisemnej zgody Dell Inc. jest surowo zabronione.

Dell i logo DELL to znaki towarowe firmy Dell Inc. Firma Dell nie zgłasza żadnych praw do marek i nazw innych firm.
 sierpień 2004

本指南的內容如有變更，恕不另行通知。
 © 2004 Dell Inc. 版權所有。

未經 Dell Inc. 的書面許可，嚴禁任何形式的非法複製。

Dell 及 DELL 標誌為 Dell Inc. 的商標。Dell 對其他 Dell 公司的商標和名稱的所有權均不為 Dell 所有。
 2004年8月

